

Mobile Columns

EHB® 905V11DC wireless



Mobile lifting column

Model:	EHB905V11DC
Article no.:	EHB905V11DC01-H
Capacity:	5.5 t
Load support:	Length of fork 385 mm, adjustable for wheels ø 550 – 1140 mm
Lifting stroke:	1750 mm (effective)
Lifting / lowering time:	Approx. 70 sec.
Operation:	Control panel with LCD screen display
Control:	Wireless communication via radio control
Drive:	Electro-hydraulic Motor 2.2 kW
Power supply:	Batteries 24 V
Charging of batteries:	EasyCharge: common charging of 4 mobile columns, integrated charging cable 10 m

 Quality made
in Germany



Version for vehicles with inboard wheels, e. g. motorhomes

Model:	Mobile column EHB905V11DC-FEX
	Length of fork 500 mm
Article no.:	EHB905V11DC01-H-FEX
Capacity:	5.5 t



Walter Finkbeiner GmbH
 Alte Poststrasse 9/11 | 72250 Freudenstadt | Germany
 Tel +49 7441 92521-0 | info@finkbeiner.eu
 www.finkbeiner.eu

The Finkbeiner company is certified by



Technical changes reserved.
 © Walter Finkbeiner GmbH 10/2022

Mobile Columns

EHB® 905V11DC wireless

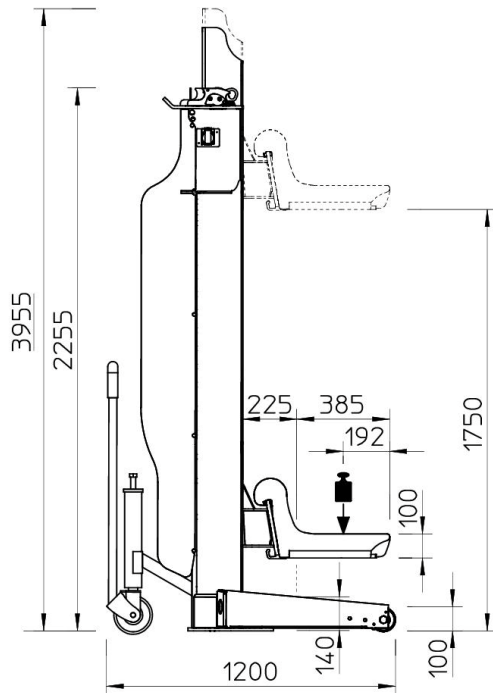

Mobile column EHB905V11DC
Length of fork 385 mm

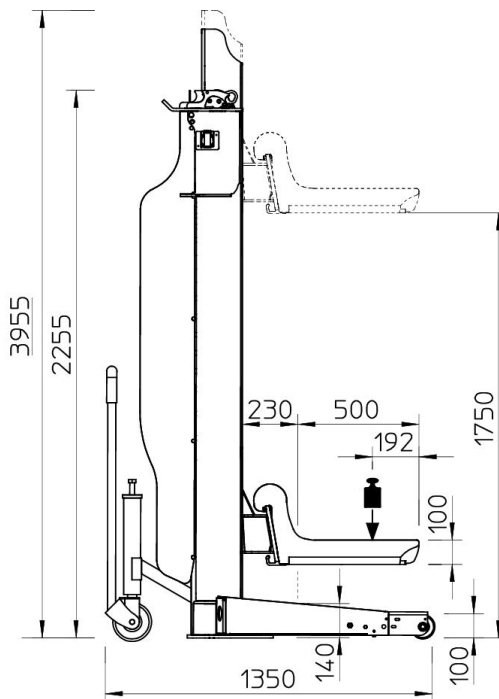

Mobile column EHB905V11DC-FEX
Length of fork 500 mm



Walter Finkbeiner GmbH
Alte Poststrasse 9/11 | 72250 Freudenstadt | Germany
Tel +49 7441 92521-0 | info@finkbeiner.eu
www.finkbeiner.eu

The Finkbeiner company is certified by



Technical changes reserved.
© Walter Finkbeiner GmbH 10/2022