



# AUTOEDU

Automotive technical education equipment





# AutoEDU

**Baltijos Automobilių Diagnostikos Sistemos JSC (Baltic Automotive Diagnostic Systems) – B.A.D.S.** was founded in the year 2001. Company has started its business as a trading company selling automotive diagnostic equipment. After several years the company has expanded its range of products and services and started selling automotive garage equipment for cars and commercial vehicles. In the year 2005 the company started manufacturing vocational automotive training equipment under the AutoEDU brand. We design and manufacture automotive training equipment and other automotive educational products for automotive technology teaching and training.

Since 2004 our company has been organizing automotive diagnostic training courses in our own training center. During the training there was a need for automotive training and demonstrational equipment which could show and explain different automotive technologies, possibilities of measuring and diagnostic tools for fault searching and repairing.

Our manufactured automotive training equipment is a great tool for students of technical subjects to understand the working processes in various automotive systems and explore different sensors, actuators, other devices and their functions. By using our manufactured equipment students are able to learn how to perform various measurements, read and understand technical documentation, schematics, wiring diagrams, error codes, signal characteristics and diagnostic procedures.

The majority of automotive teachers of Lithuanian practical and vocational training centers, agricultural schools and colleges have completed our training courses. Their observations and practical experience helped us shape and adapt (customize) our automotive training equipment production for automotive mechanics and various diagnostic educational programs.

Long lasting cooperation between our company and different automotive vocational schools, training centers and technical colleges help us provide them optimal, "up to date" high performance training products and solutions, suitable for their needs in different training programs.

## Our products

Our company designs and manufactures automotive training equipment. Our product range consists of:

Cars and trucks self – contained, fully operational engines with different fuel supply systems: petrol (MPI, FSI, TFSI, TSI and etc.), diesel (TD, TDI, Common Rail, PD, PLD and etc.) and hybrid petrol electric drive system. All our manufactured operational engines are available with pin-out facilities and fault simulation to assist students in the diagnostic training and to help them understand modern vehicle systems.

Training boards-simulators are based on OEM components and specially designed to help technical students understand better structure and components of automotive systems: engine control system (petrol and diesel), ABS, SRS and etc.

Functional models are fully operational educational tools in space saving version of a complete car with all its advantages. Cutaway models of automotive components: engines, gearboxes and etc.

Custom made products. We manufacture customized testing equipment to control and test automatic gearboxes for Mercedes Benz cars and DSG gearboxes of VAG group cars. According to special needs of the customer we manufacture custom equipment for demonstration of specific diagnostic equipment.

All **AutoEDU** training equipment is based on OEM components. The systems which are used in our products are original, only in exceptional cases the components can be simulated. The electrical signals or diagnostic procedures are simulated on working conditions as in a real car. As a result, automotive training equipment with all technical specifications and functions is very close to a real vehicle. By using AutoEDU automotive training equipment in different training programs vocational training becomes more interesting and practical for the students.

## Our customers

Automotive technical schools, vocational schools, technical colleges, academies, agriculture schools, private technical training organizations, diagnostic equipment and workshop equipment manufacturers, diagnostic equipment and garage equipment suppliers and wholesalers.

## Our experience

Most of the company's employees have completed courses in training centers of such companies as AUTOCOM, TEXA, SNAP-ON, BOSCH, Brainbee, Jaltest and etc. Since 2004 our company has its own training center and we train our customers how to perform automotive repairs and diagnostics. Since 2005 we have modernized and successfully completed equipment installations in more than 25 educational institutions. (Our biggest sales contract exceeded more than 1.100.000 Euro).

## Our foreign partners and the first steps of export

The company has trade partners and representatives for AutoEDU products in such countries as Germany, United Kingdom, Ireland, Brazil, Egypt, Malaysia, India, Japan, Indonesia, Czech Republic, Slovakia, Palestine, Latvia, Italy and others. During the short period of time AutoEDU automotive training equipment attracted attention of such companies which have experience in automotive training equipment industry more than 50 years.

The company presented their products and participated in several international exhibitions such as: AUTOMECHANIKA MIMS Moscow (Russia), AUTO & Korjaamo Helsinki (Finland), AUTOMECHANIKA Frankfurt (Germany) and WORLD DIDAC Basel (Switzerland). The company's production was positively evaluated by their partners, potential clients and even by a few competitors.

Since 2014 the company has discovered export markets and already enjoys that automotive training stands were sold and positively assessed in such countries as Germany, India, Australia, Latvia, Vietnam, Peru, Oman, Japan, etc.

**AUTOEDU**

Automotive training equipment



[www.automotivetrainingequipment.com](http://www.automotivetrainingequipment.com)



# ENGINE CONTROL SYSTEM BOSCH MOTRONIC MED 7.5.10 (FSI) TRAINING BOARD-SIMULATOR

Fully functional engine control system is installed in a mobile aluminum frame. This training board-simulator is specially designed to help technical students understand better direct petrol injection (FSI) system MOTRONIC MED 7.5.10. The educational training board is based on OEM components of Audi/VW. The integrated engine control system shows different operation modes of the direct fuel injection/ ignition system.

The training board-simulator is a great educational tool that allows students to learn the structure of the engine control system, study its components and operation modes, perform various measurements, tests and other diagnostic procedures.

## Technical specifications and functions

- The integrated engine control system with direct petrol injection (FSI)
- Monitoring operation of fuel supply system, injected fuel quantity, spray pattern quality, low fuel pressure of the fuel pump
- Low pressure fuel pump is built into a transparent tank which allows to see its operation
- The adjustable air flow rate simulator demonstrates the function of the mass - air flow meter and air temperature sensor
- Visible work process of spark plugs
- Easy access for high voltage measurements
- Manual adjustment of the engine crankshaft speed
- Integrated simulators allow changes to the parameters of each system component:
  - Lambda probe signal simulation;
  - Engine operation temperature simulation;
  - NOx sensor parameter simulation;
  - Exhaust gas temperature sensor simulation;
  - Intake manifold pressure sensor simulation;
- The training board has a complete electric wiring diagram of direct petrol injection system (FSI)
- Electric wiring diagram with built – in banana plug jumpers for measurements and simulation of system fault codes; Ability to monitor the changing operation mode of each system component
- Ability to simulate more than 20 system faults by disconnecting Banana plug jumpers
- Training board has an integrated TFT voltmeter. It displays voltage of different electronic system components:
  - G212 Exhaust gas recirculation potentiometer
  - G70 Air-mass flow meter
  - G185 Accelerator pedal position sender I
  - G79 Accelerator pedal position sender II
  - G336 Intake manifold flap potentiometer
  - G247 Fuel pressure sensor
  - G187 Throttle valve potentiometer I
  - G188 Throttle valve potentiometer II
  - G71 Intake manifold pressure sensor
  - G62 Engine operation temperature sensor
  - G83 Coolant temperature sensor
  - G235 Exhaust gas temperature sensor
- Intake manifold flap regulation (vacuum pump is required, optional)

Order No.: MSFSI 1

Changes reserved!

## Diagnostic and measurement

### Oscilloscope/multimeter

- System's parameters are measured by connecting to the banana connector
- Ability to measure electrical signal parameters of each system component (such as sensor or actuator)
- Ability to measure high voltage circuit of the ignition system

### Control unit diagnosis

- Diagnosis through OBD 16 – pin diagnostic connector
- Electronic control unit (ECU) identification
- Reading/erasing fault codes
- Displaying the operating system parameters (live data)
- Activating the actuators (Depends on the control unit)
- Throttle valve adaptation
- Control unit encoding/configuration

### Other

- The stand has a closed structure – internal wiring is not visible
- Power supply: 220V
- Dimensions approx.: (HxLxW) 1820x1360x500mm
- Nett weight approx.: 105 Kg
- Made in Lithuania
- CE certificate

### Optional accessories

- Examination console for 10 hidden fault simulations
- Vacuum / pressure pump
- Automotive oscilloscope
- OBD diagnostic scan tool

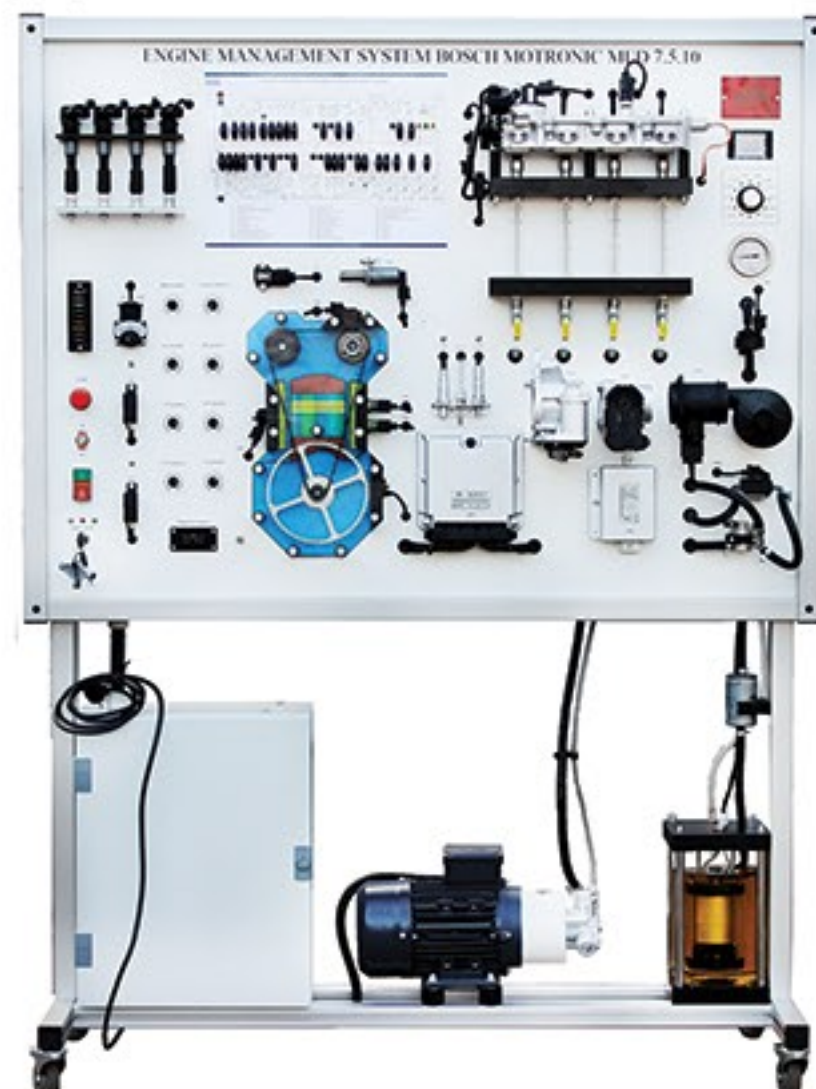



# ENGINE CONTROL SYSTEM MOTRONIC M 3.8.X (MPI) TRAINING BOARD-SIMULATOR

Fully functional engine control system is installed in a mobile aluminum frame. This training board-simulator is specially designed to help technical students understand better multipoint petrol injection (MPI) system MOTRONIC M 3.8.X. The educational training board is based on OEM components of Audi/VW. The integrated engine control system shows the different operation modes of the fuel injection/ ignition system.

The training board-simulator is a great educational tool that allows students to learn the structure of engine control system, study its components and operation modes, perform various measurements, tests and other diagnostic procedures.

## Technical specifications and functions

- The integrated engine control system with multipoint petrol injection system (MPI)
- Monitoring operation of fuel supply system, injected fuel quantity, spray pattern quality, fuel pressure of the fuel pump
- Fuel pump is built into a transparent tank which allows to see its operation
- The adjustable air flowrate simulator demonstrates the function of the work of mass - air flow meter and air temperature sensor
- Visible work process of spark plugs
- Easy access for high voltage measurements
- Manual adjustment of the engine crankshaft speed
- Ability to change the air/fuel mixture by the oxygen sensor signal simulator
- The training board has a complete electric wiring diagram of multipoint petrol injection system (MPI)
- Electric wiring diagram with built in banana plug jumpers for measurements and simulation of system fault codes
- Ability to simulate more than 20 faults by disconnecting Banana plug jumpers

## Diagnostic and measurement

### Oscilloscope/multimeter

- System's parameters are measured by connecting to the banana connector
- Ability to measure electrical signal parameters of each system component (such as sensor or actuator)
- Ability to measure high voltage circuit of the ignition system

### Control unit diagnosis

- Diagnosis through OBD 16 – pin diagnostic connector
- Electronic control unit (ECU) identification
- Reading/erasing fault codes
- Displaying the operating system parameters (live data)
- Activating the actuators (Depends on the control unit)
- Throttle valve adaptation
- Control unit encoding/configuration

### Other

- The stand has a closed structure – internal wiring is not visible
- Power supply: 12V from the battery or power supply unit (battery and power supply unit are not included as standard accessories)
- Dimensions approx.: (HxLxW) 1820x1360x500mm
- Nett weight approx.: 70 Kg
- Made in Lithuania
- CE certificate

## Optional accessories

- Examination console for 10 hidden fault simulations
- 12 V battery
- 220/12 V Power supply unit

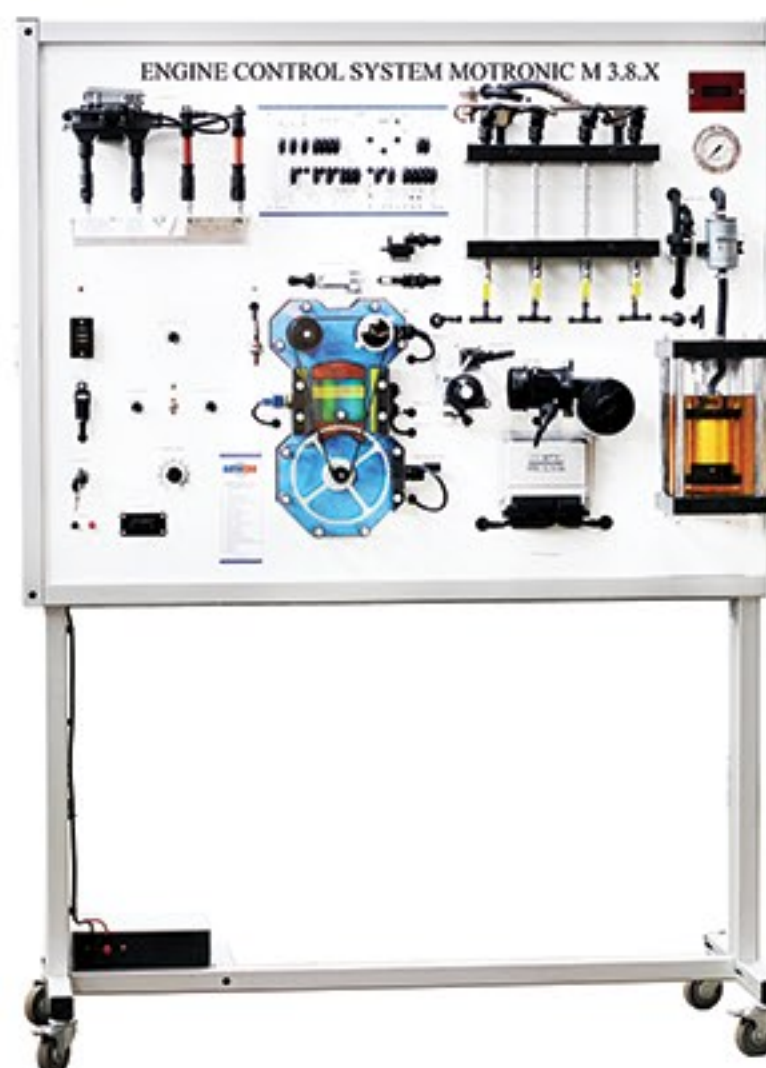

Order No.: MSMPI 1

Changes reserved!



# DIESEL ENGINE CONTROL SYSTEM CR/EDC 15C3-4.1 TRAINING BOARD – SIMULATOR

Fully functional engine control system is installed in a mobile aluminum frame. This training board-simulator is specially designed to help technical students understand better system of diesel injection Common Rail.

The educational training board is based on OEM components of Renault. The integrated engine control system Bosch EDC 15 shows different operation modes of the direct fuel injection system.

The training board-simulator is a great educational tool that allows students to learn the structure of engine control system, study its components and operation modes, perform various measurements, tests and other diagnostic procedures.

## Technical specifications and functions

- Integrated engine control system with diesel Common Rail direct injection
- The stand consists of two parts: one is designed to demonstrate the work of the high pressure pump and the injectors, the other – to demonstrate the electronic engine management system. Both parts are electrically interconnected and operate as a single system
- Monitoring operation of high pressure fuel supply system, injected fuel quantity, the amount of fuel back leak, spray pattern quality
- The adjustable air flow rate simulator demonstrates the function of the mass - air flow meter and air temperature sensor
- Manual adjustment of the engine crankshaft speed
- Integrated simulators allow changes to the parameters of engine temperature sensor
- Integrated simulators allow changes to the parameters of intake air pressure sensor
- Electric wiring diagram with built – in banana plug jumpers for measurements and simulation of system fault codes; Ability to monitor the changing operation mode of each system component
- Ability to simulate more than 20 faults by disconnecting Banana plug jumpers
- The training board has integrated TFT voltmeter. It displays voltage of electronic system components:
  - APPS1 Accelerator pedal position sender I
  - APPS2 Accelerator pedal position sender II
  - ACT Air charge temperature sensor
  - MAF Air – mass flow meter
  - FPS Fuel high pressure sensor
  - MAP Intake manifold pressure sensor
  - EGR Exhaust gas recirculation potentiometer
  - CTS Engine coolant temperature sensor
  - FTS Fuel temperature sensor

## Diagnostic and measurement

### Oscilloscope/multimeter

- System's parameters are measured by connecting to the banana connector
- Ability to measure electrical signal parameters of each system component (such as sensor or actuator)

### Control unit diagnosis

- Diagnosis through OBD 16 – pin diagnostic connector
- Electronic control unit (ECU) identification
- Reading/erasing fault codes

- Displaying the operating system parameters (live data)
- Activating the actuators (Depends on the control unit)
- Control unit encoding/configuration

### Other

- The stand has a closed structure – internal wiring is not visible
- Power supply: 220/12 V
- Dimensions approx.: (HxLxW)
- Electronic part (board) 1820x1360x500mm
- Mechanical part (trolley) 1500 x 800 x 500 mm
- Nett weight approx.: 135 Kg
- Made in Lithuania
- CE certificate

### Optional accessories

- Examination console for 10 hidden fault simulations
- Automotive oscilloscope
- OBD diagnostic scan tool



Order No.: MSCR 1

Changes reserved!



# SRS BOSCH AB 8.4 (AIRBAG) TRAINING BOARD-SIMULATOR

Fully functional supplemental restraint system is installed in a mobile aluminum frame. This training board-simulator is specially designed to help technical students understand better the system's construction.

The educational training board is based on OEM components of Audi/VW. The stand is equipped with a functional car safety system SRS BOSCH AB 8.4 (AIRBAG). The training board-simulator is a great educational tool that allows students to learn the structure of supplemental restraint system, study its components, perform various measurements, tests and other diagnostic procedures.

## Technical specifications and functions

- The training board is equipped with a safety SRS BOSCH AB 8.4 (Airbag) system that includes four air bags, crash sensors, mechanism of air bag steering wheel module and spiral cable, front seat belts with igniters and tensioners, rear seat belts and two control units
- Cutaway technology of the passenger's side airbag and control unit allows to see the structure of the components
- Integrated inactive airbag igniters (after activation)
- The training board is integrated with two safety system control units. One functional – with diagnostic possibilities, second – after activation, with recorded crash data
- Electric wiring diagram with built in banana plug jumpers for measurements and simulation of system fault codes
- Ability to simulate more than 10 system faults by disconnecting Banana plug jumpers

## Diagnostic and measurement

### Oscilloscope/multimeter

- System's parameters are measured by connecting to the banana connector
- Ability to measure electrical signal parameters of each system component

### Control unit diagnosis

- Diagnosis through OBD 16 - pin diagnostic connector
- Electronic control unit (ECU) identification
- Reading/erasing fault codes
- Displaying the operating system parameters (live data)
- Activating the actuators (Depends on the control unit)
- Control unit encoding/configuration

### Other

- The stand has a closed structure – internal wiring is not visible
- Power supply: 12V from the battery (not included as standard accessory)
- Dimensions approx.: (HxLxW) 1820x1360x500mm
- Nett weight approx.: 60 Kg
- Made in Lithuania
- CE certificate

### Optional accessories

- 12 V battery
- 220/12 V Power supply unit
- Automotive oscilloscope
- OBD Diagnostic tool



Order No.: MSSRS 1

Changes reserved!



# ABS ANTI – LOCK BRAKING SYSTEM BOSCH ABS 5.3 TRAINING BOARD – SIMULATOR

Fully functional ABS anti-lock braking system is installed in a mobile aluminum frame. This training board-simulator is specially designed to demonstrate ABS anti-lock braking system and operational structure. Educational training board is based on OEM components of Audi/VW.

The stand is equipped with a functional BOSCH 5.3 ABS anti-lock braking system and shows different operation modes. The training board simulator is a great educational tool that allows students to learn the structure of ABS control system, study its components, perform various measurements, tests and other diagnostic procedures.

## Technical specifications and functions

- The training board is equipped with a functional BOSCH 5.3 ABS anti-lock braking system
- With installed pressure gauges it is possible to monitor the pressure in the main brake circuit and the individual pressure of each wheel
- The training board is equipped with original hydraulic brake system. The brake pads of the brake drums are used instead of the brake discs to see, when the pressure rises up and the braking moment starts
- The operation of the hydraulic circuit is shown on the stand in the pictures in different modes
- Electric wiring diagram with built – in banana plug jumpers for measurements and simulation of the system's fault codes

## Diagnostic and measurement

### Oscilloscope/multimeter

- System's parameters are measured by connecting to the banana connector
- Ability to measure electrical signal parameters of each system component

### Control unit diagnosis

- Diagnosis through OBD 16 – pin diagnostic connector
- Electronic control unit (ECU) identification
- Reading/erasing fault codes
- Displaying the operating system parameters (live data)
- Activating the actuators (Depends on the control unit)

### Other

- The stand has a closed structure – internal wiring is not visible
- Power supply: 12 V from the battery (not included as standard accessory)
- Dimensions approx.: (HxLxW) 1820x1360x500mm
- Nett weight approx.:70 Kg.
- Made in Lithuania
- CE certificate

### Optional accessories

- 12 V Battery
- 220/12 V power supply unit
- Automotive oscilloscope
- OBD Diagnostic scan tool

Order No.: MSABS 1

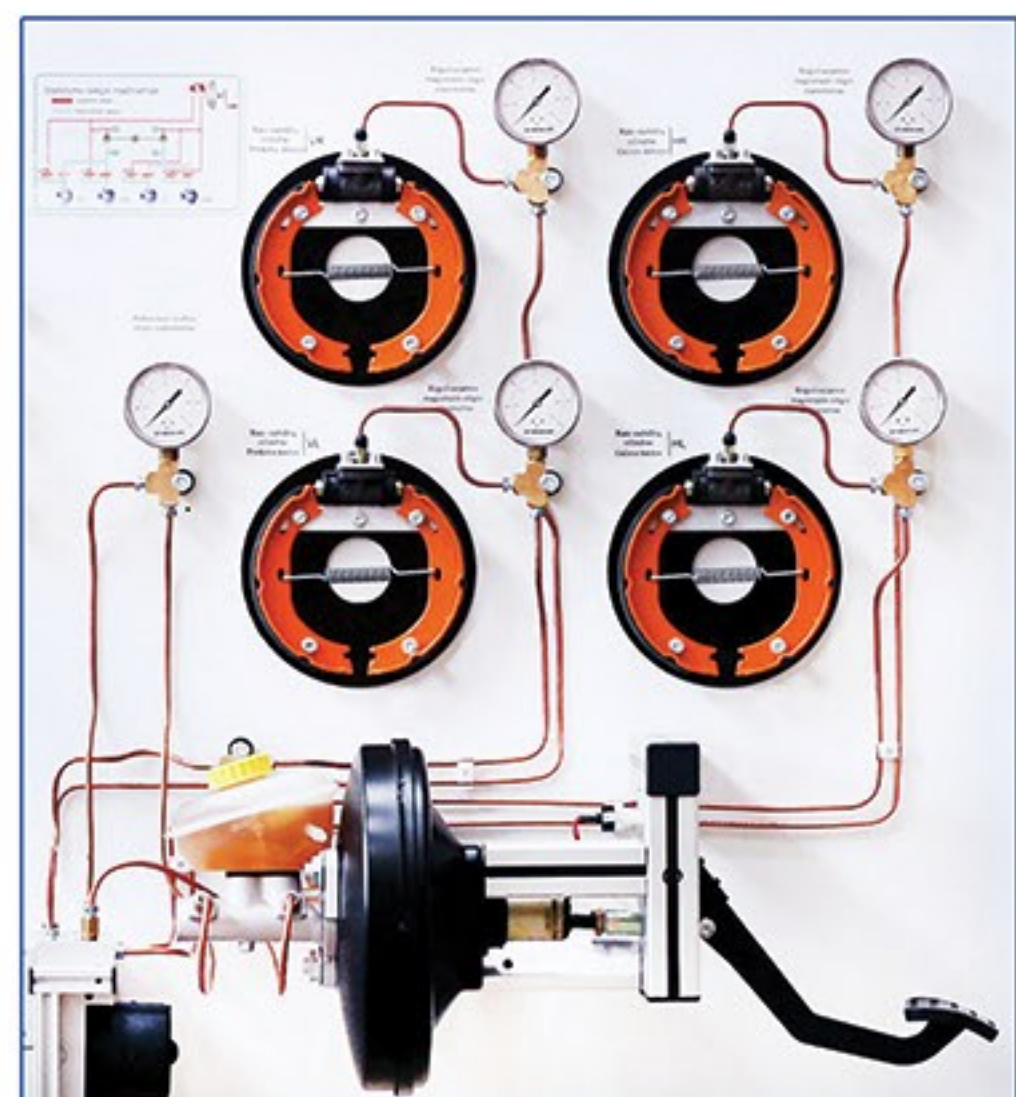

Changes reserved!



# BRAKING SYSTEM RIG

Fully functional, cross diagonal, hydraulic braking system with ABS is installed in a mobile solid frame. The training brake rig is specially designed to demonstrate hydraulic braking system with electronic ABS system and brake booster. The educational automotive training stand is based on Audi/ VW components. The trainer is equipped with a functional ABS braking system and shows the different operation modes.

The training brake rig is a great educational tool that allows students to learn the structure of hydraulic braking system, study its components, perform various measurements, tests and other service and diagnostic procedures.

The training brake rig can be used as visual aid for students of mechanical subjects to demonstrate and explain the structure and components. Also, automotive training stand can be used as an educational equipment for the brake system repair and service procedures.

AutoEDU training brake rig is equipped with ABS modulator and brake booster. The increase of braking force after connecting vacuum can be demonstrated using the brake booster. With installed four pressure gauges it is possible to monitor the pressure in the brake circuit of each wheel. Simulation of blocking (slipping) wheel in a drive mode allows to monitor ABS system demonstration. With installed pressure gauges the brake force distribution and foot brake pedal rejection can be monitored when ABS system is activated.

The training rig has an integrated OBD 16 – pin diagnostic connector that allows to connect with the diagnostic tool and perform various measurements, tests and other diagnostic procedures such as reading fault codes, displaying the operating systems parameters and other.

## Technical specifications and functions

- Clearly visible fully functional braking system and its components
- Cross diagonal hydraulic braking system with front and rear discs with calipers
- Functional parking brake
- Functional electronic ABS system
- Functional brake booster
- With installed pressure gauges the pressure can be monitored in the brake circuit of each wheel
- Driving mode simulation
- Brake rigs can be used for mechanical service and repair training
- On-board diagnostic capabilities
- AUTOEDU brake rigs can perform all routine brake service such as component replacement, adjustments or hydraulic bleeding procedures

## Diagnostic and measurement

### Control unit diagnosis

- Diagnosis of electronic ABS system through OBD diagnostic connector
- Electronic control unit (ECU) identification
- Reading/erasing fault codes
- Displaying the operating system parameters (live data)
- The air bleeding mode in a braking system

### Other

- Power supply: 12 V from the battery (not included as standard accessory)
- Dimensions (height x length x width) 1250x1000x750mm
- Nett weight approx.: 99 Kg
- Made in Lithuania
- CE certificate

### Optional accessories

- 12 V Battery
- OBD Diagnostic scan tool
- Standard tool kit for mechanic
- Special tools for brake system repairs
- Vacuum pump

Changes reserved!



Order No.: MSSS01



# CAN BUS TRAINING STAND

Fully functional CAN – BUS network system is installed in a mobile aluminum frame. This training board-simulator is specially designed to help technical students understand better the system`s construction.

The educational training board is based on Mercedes – Benz components. The stand is equipped with a functional CAN GATEWAY 2.0 system.

Training board-simulator is a great educational tool that allows students to learn the structure of CAN gateway system, study its components, perform various measurements, tests and other diagnostic procedures.

## Technical specifications and functions

- Training board is equipped with a CAN gateway 2.0 network system that includes
  - Dashboard
  - Engine ECU
  - Smart Key, ignition module, lock module
  - SRS Airbag ECU
  - Central CAN Gateway module (ECU)
  - Front and rear doors control modules
  - Front and rear windows lifting motors
  - Front and rear windows lifting switches
- All the components are connected to the internal network. The network is shown as a diagram in order to understand better
- The modules communication can be connected or disconnected by banana plug jumpers. Low and High speed CAN lines connected or disconnected on the stand
- CAN gateway diagram with built in banana plug jumpers for measurements and simulation of system malfunctions
- Ability to simulate more than 10 system faults
- The window lifting motors are active and controlled by switches and doors control modules
- Through CAN gateway network of the car

## Diagnostic and measurement

### Oscilloscope/multimeter

- System's parameters are measured by connecting to the banana connector
- Ability to measure electrical signal parameters of system component

### Control unit diagnosis

- Diagnosis through OBD 16 - pin diagnostic connector
- Diagnose all presented control units in the CAN bus network by using an automatic search (depending on the diagnostic tool possibilities)
- Diagnose of each control module separately
- Electronic control unit (ECU) identification
- Reading/erasing fault codes
- Displaying the operating system parameters (live data)
- Activating the actuators (Depends on the control unit)
- Control unit encoding/configuration (Depends on the control unit)

### Other

- The stand has a closed structure – internal wiring is not visible
- Power supply: 12V from the battery (not included as standard accessory)
- Dimensions approx.: (HxLxW) 1820x1360x500mm
- Nett weight approx.: 60 Kg
- Made in Lithuania
- CE certificate

### Optional accessories

- 12 V battery
- 220/12 V Power supply unit
- Automotive oscilloscope
- CAN Network analyzer
- OBD diagnostic scan tool



Order No.: MSCAN 1

Changes reserved!



# AIR CONDITIONER SYSTEM CLIMATRONIC TRAINING BOARD

Fully functional air conditioning and climate control system trainer is installed in a mobile aluminium frame. This training board – simulator is specially designed to help technical students understand better electronic air conditioning and climate control system CLIMATronic. The educational training board is based on Audi/VW OEM components. The integrated air conditioning and climate control system shows the different operation modes.

The training board-simulator is a great educational tool that allows students to learn the structure of air conditioning and climate control system, study its components, and perform various measurements, tests and other diagnostic procedures to use diagnostic scan tools or other special tools and equipment.

## Technical specifications and functions

- Integrated electronic air conditioning system with climate control (Climatronic)
- Monitoring operation modes of air conditioning and climate control system
- Visible HVAC compressor, electromagnetic compressor clutch and its operation modes
- With installed pressure gauges it is possible to monitor the pressure distribution of R134a refrigerant in the high and low pressure sides (circuits)
- Visible HVAC (heating, ventilating and air conditioning) mixing unit with its operation modes
- Visible the operation of air flow flaps
- Ability to monitor and control changes to the parameters of each system component:
  - The air flow fan speed
  - The air flow flap positions
  - The interior (inside) temperature
  - The Refrigerant R134a pressure changes depending on the speed of the cooling radiator fan
    - The rate of the temperature change depending on the speed of the air flow radiator fan
    - The air flow flap position according to operation modes: defrost, air recirculation (fresh air) or footwell
- The training board has a diagram with LED's which shows the operation modes of the outlets and flaps
- The training board has a complete electric wiring diagram with built - in banana plug jumpers for measurements and simulation of the system fault codes
- Ability to simulate more than 15 system faults by disconnecting banana plug jumpers. Ability to monitor the changing operation mode of each system component;
- The training board has integrated voltmeter. It displays voltage of electronic system components:
  - G92 Control motor potentiometer for temperature flap
  - G114 Control motor potentiometer, footwell/defroster flap
  - G112 Control motor potentiometer, central flap
  - G113 Control motor potentiometer, air flow flap
  - G89 Fresh air intake duct temperature sensor
  - G191 Vent. temperature sender, center
  - G192 Vent. temperature sender, footwell
  - G17 Ambient temperature sensor
- The integrated thermometer displays the temperature change depending on the pressure of the refrigerant R134a

## Diagnostic and measurement

### Oscilloscope/multimeter

- System's parameters are measured by connecting to the banana connector

Changes reserved!

- Ability to measure electrical signal parameters of each system component (such as sensor or actuator)

### Control unit diagnosis (with the scan tool)

- Diagnosis through OBD 16 – pin Diagnostic connector:
- Electronic control unit (ECU) identification
- Reading/erasing fault codes
- Displaying the operating system parameters (live data)
- Activating the actuators (Depends on the control unit)
- Control unit encoding/configuration (Depends on the control unit)

### Control unit diagnosis (manual procedures without the scan tool)

- Manual diagnostics of Climatronic ECU
- Error reading - manual procedures
- Displaying the operating system parameters (live data) - manual procedure

### Other

- The stand has a closed structure – internal wiring is not visible
- Power supply: 220V
- Dimensions approx.: (HxLxW): 1680x800x500mm;
- Nett weight approx.: 100 Kg;
- Made in Lithuania
- CE certificate

### Optional accessories

- Automotive oscilloscope
- OBD Diagnostic scan tool
- Air conditioning recharge station



Order No.: MSC1, MSC 2



# DUAL ZONE AIR CONDITIONING AND CLIMATE CONTROL TRAINER WITH AUXILIARY HEATER

Fully functional dual zone air conditioning and climate control system trainer is installed in a mobile aluminium frame. This training board – simulator is specially designed to help technical students understand better electronics, mechanics, the theory of air conditioning and climate control system. The educational training stand is based on Audi/VW OEM components. The integrated air conditioning and climate control system shows the different operation modes. The training board-simulator is a great educational tool that allows students to learn the structure of air conditioning and climate control system, study its components, perform various measurements, tests and other diagnostic procedures to use diagnostic scan tools or other special tools and equipment. In order to show all the functions of climate control this educational aid has installed the auxiliary heating unit which could be petrol or diesel.

## Technical specifications and functions

- Integrated electronic 2C – Climatronic heating and air conditioning system
- Monitoring operation modes of air conditioning and climate control system
- Visible HVAC compressor, electromagnetic compressor clutch and its operation modes
- With installed pressure gauges it is possible to monitor the pressure distribution of R134a refrigerant in the high and low pressure sides (circuits)
- Visible HVAC (heating, ventilating and air conditioning) mixing unit with its operation modes Visible the operation of airflow flaps
- Ability to monitor and control changes to the parameters of each system component:
  - The air flow fan speed
  - The air flow flap positions
  - The interior (inside) temperature
  - The Refrigerant R134a pressure changes depending on the speed of the cooling radiator fan
    - The rate of the temperature change depending on the speed of the airflow radiator fan
    - The air flow flap position according to operation modes: defrost, air recirculation (fresh air) or footwell
  - The training stand has a complete electrical wiring diagram with built-in banana plug jumpers for measurements and simulation of the system fault codes
  - Ability to simulate more than 15 system faults by disconnecting banana plug jumpers. Ability to monitor the changing operation mode of each system component
  - The training stand has integrated auxiliary heating unit which could be petrol or diesel on request. The heating unit delivers heated coolant fluid to the heating exchange unit to enable the climate control run and show how it cools or heats the air

## Diagnostic and measurement

### Oscilloscope/multimeter

- System's parameters are measured by connecting to the banana connector
- Ability to measure electrical signal parameters of each system component (such as sensor or actuator)

### Control unit diagnosis (with the scan tool )

- Diagnosis through OBD 16 – pin diagnostic connector
- Electronic control unit (ECU) identification
- Reading/erasing fault codes

Order No.: MSC3-B | MSC3-D

Changes reserved!

### Control unit diagnosis (with the scan tool)

- Displaying the operating system parameters (live data)
- Activating the actuators (depends on the control unit)
- Diagnosis of auxiliary heating unit through the specific diagnostic socket

### Other

- Power supply: 220V
- Made in Lithuania
- CE certificate

### Optional accessories

- Automotive oscilloscope
- OBD Diagnostic scan tool
- Auxiliary heating unit diagnostic interface
- Air conditioning recharge station

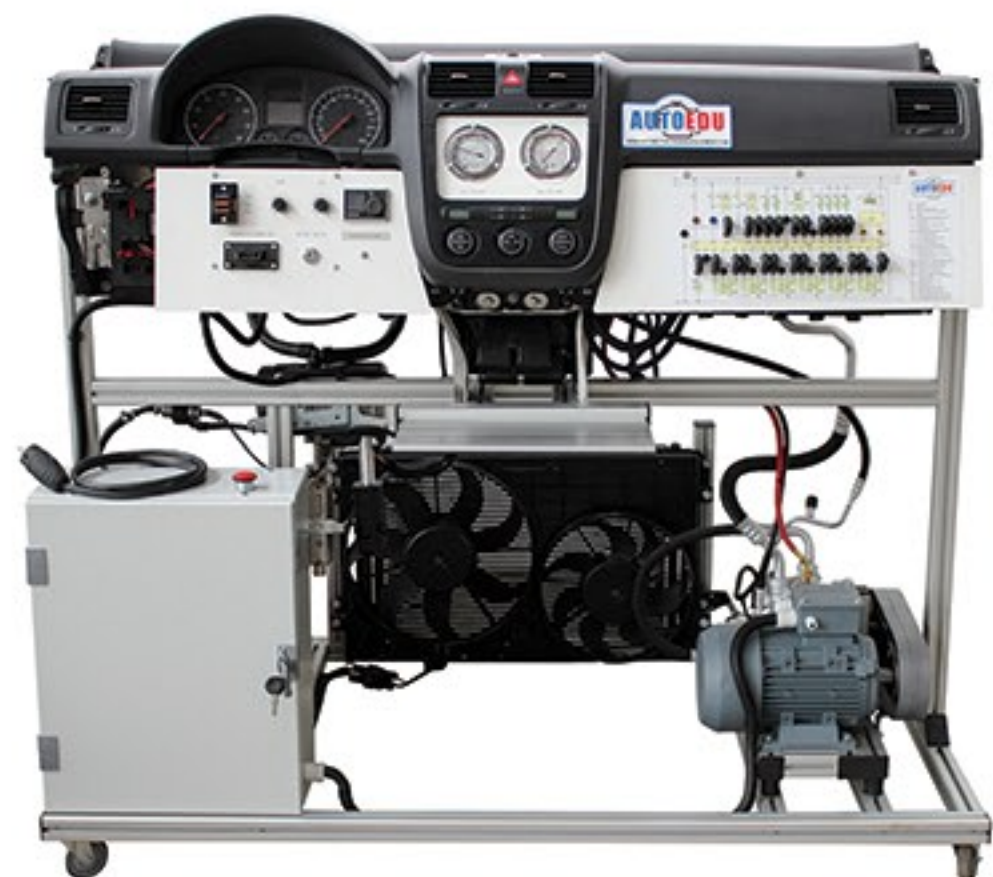



# EDUCATIONAL TACHOGRAPH SIMULATORS

## DIGITAL AND ANALOGUE

**Digital Tachograph Simulator.** The educational equipment, training box is based on OEM components. Fully functional system is specially designed to train truck drivers and students to learn about different truck tachograph usage and operation modes.

### General characteristics of EFAS Training Box:

#### Training Box Digital Tachograph:

- Fully functional system
- Driving speed simulation
- Rest and driving time modes
- Printouts of driving reports
- Delivered ready to use
- Illuminated screens
- Suitable for transportation and storage
- Light case with carrier handle

#### The Training Box comes with:

- EFAS User guide (English/German/Russian/Lithuanian)
- EFAS Quickstart guide (ENG)
- Driver card
- Workshop card
- Company card
- Thermal printer paper rolls
- Power supply pack
- EFAS training unit
- Impulse transmitter
- Made in EU
- Dimensions approx. (HxLxW): 38 x 37 x 24 Cm
- Nett weight approx.: 6 Kg



Order No.: MSTACH02



Changes reserved!

**Analogue tachograph.** An educational analogue truck tachograph with paper disc charts is a great educational tool for students of automotive technical subjects and truck drivers to learn about different analogue truck tachograph usage and operation modes. The device is delivered to the educational institution ready for use. The educational analogue tachograph with the paper charts is based on OEM components.

### General characteristics of analogue tachograph:

#### General characteristics of analogue tachograph:

- Fully functional system
- Driving speed simulation
- Rest and driving time modes are shown on a paper disc charts
- Delivered ready to use
- Illuminated screens
- Suitable for transportation and storage
- Light case with carrier handle

#### The Training Box comes with:

- Educational analogue tachograph
- User guide
- Tachograph paper disc charts
- Power supply pack
- Impulse transmitter
- Made in EU
- Dimensions approx. (HxLxW): 38 x 37 x 24 Cm
- Netto weight approx.: 6 Kg



Order No.: MSTACH03



# LIGHTING TRAINING STAND

Fully functional lighting training system is installed in a mobile aluminum frame.

The educational training board is based on VW/AUDI components. The training board-simulator is a great educational tool that allows students to learn the structure of lighting system, study its components, and perform various measurements, tests and other diagnostic procedures.

## Technical specifications and functions

- Electric wiring diagram with built – in banana plug jumpers for measurements and connecting or disconnecting the components
- Open contacts for measuring of system's components and circuits
- Diagnosis through OBD (J1962) 16 – pin diagnostic connector (Dashboard only)
- Adjustable beam levels with the motors of front headlights
- Possible adjustments training with the headlight tester (optional)



## Diagnostic and measurement

### Oscilloscope/multimeter

- Ability to measure electrical signal parameters of system component

### Control unit diagnosis

- Diagnosis through OBD (J1962) 16–pin diagnostic connector
- Electronic control unit (ECU) identification
- Reading/erasing fault codes
- Displaying the operating system parameters (live data)
- Activating the actuators (depends on the control unit)

### Other

- The stand has a closed structure – internal wiring is not visible
- Power supply: 12V from the battery (optional)
- Dimensions approx.: (HxLxW) 1820x1360x500mm
- Nett weight approx.: 60 Kg
- Made in Lithuania
- CE certificate

### Optional accessories

- 12 V battery
- 220/12 V Power supply unit
- Automotive oscilloscope
- OBD diagnostic scan tool

Order No.: MSAS1

# SENSORS AND ACTUATORS TRAINING STAND

Educational training board is based on OEM components of different vehicles.

The training board-simulator is a great educational tool that allows students to study its components, and perform various measurements, tests and other diagnostic procedures.

## Diagnostic and measurement

### Oscilloscope/multimeter

- Ability to measure electrical signal parameters of system component

### Other

- The stand has a closed structure – internal wiring is not visible
- Power supply: 12V from the battery (optional)
- Dimensions approx.: (HxLxW) 1820x1360x500mm
- Weight (netto) approx.: 60 Kg
- Made in Lithuania
- CE certificate

### Optional accessories

- 12 V battery
- 220/12 V Power supply unit
- Automotive oscilloscope
- OBD diagnostic scan tool

Changes reserved!



Order No.: MSD 1



# AUTOMOTIVE CHARGING SYSTEM TRAINING STAND

The AutoEDU charging system training stand is specially designed to demonstrate car's alternator's working principals which are used in modern automobiles to charge the battery and to power the electrical system when the engine on running condition. The functional alternator is driven by electrical 2,2 kW motor. The alternator is installed in the aluminum frame and covered with the plexiglass for the safety reasons. This training stand can be used to help students to understand the operation and common testing procedures. Battery charging or discharging, common problems like a negative terminal fault and etc. The possibility of adjusting the speed of the rotation of alternator give an additional information how the alternator works at different RPM. All important information is shown on 3 digital panels: charging, voltage, and RPM.

The training stand has an integrated positive and negative terminal and could be used together with another AutoEDU training stands as a charging system.

## Technical specifications and functions

- Fully functional system with the 12V alternator in light aluminum frame
- Real automotive components
- Battery charging/discharging with the alternator
- Alternator loading simulation
- Negative terminal fault simulation
- An adjustable rotation speed of the alternator
- Information panels with loading, charging, RPM and voltage
- An alternator has driven by 2,2kW, electric motor.
- Power supply: 220V
- The stand could be used as a power supply for another AutoEDU training stands
- Open contacts for measurements

### Other

- Power supply: 220V
- Made in Lithuania
- CE certificate

## Optional accessories

- Oscilloscope
- Multimeter

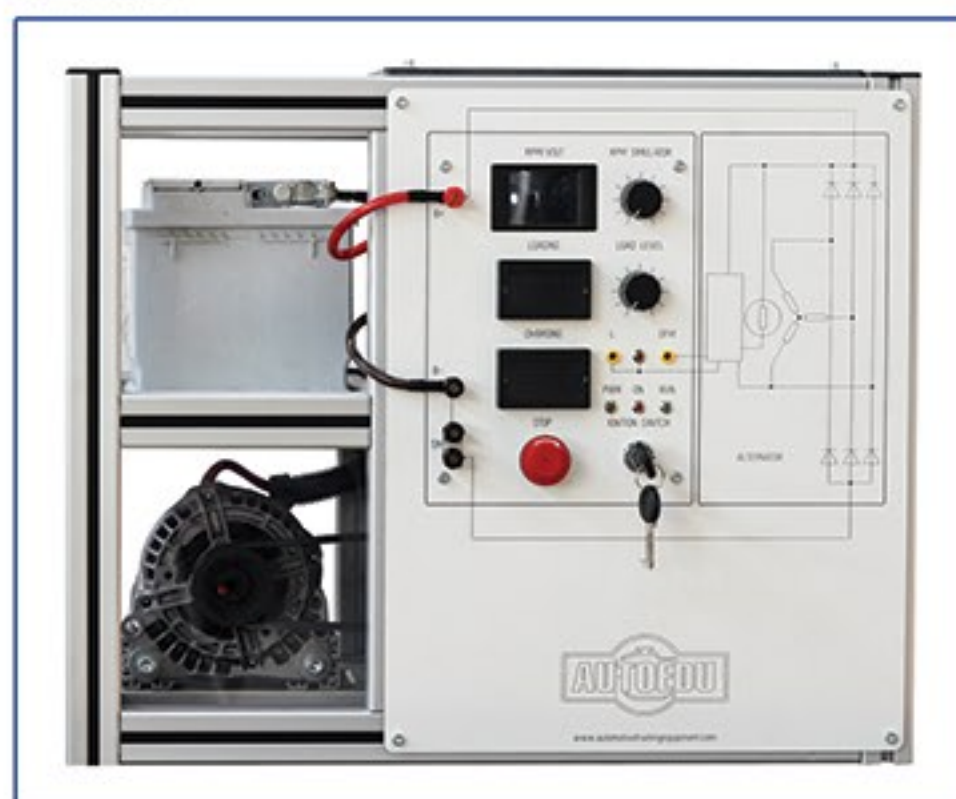

Order No.: MSMSG1

# TRUCK TRAILER WABCO EBS D 2S/2M BRAKING SYSTEM TRAINING STAND

Fully functional, truck trailer pneumatic braking system with WABCO EBS D 2S/2M is installed in aluminum frame. The training stand is specially designed to demonstrate pneumatic braking system with electronic EBS system. The educational automotive training stand is based on original Wabco components. The trainer is equipped with a functional WABCO EBS braking system and shows the different operation modes.

The training stand can be used as visual educational aid for students of mechanical subjects to demonstrate and explain the structure and components. Also, automotive training stand can be used as a training equipment for the brake system repair and service procedures.

made training brake stand is equipped with WABCO EBS modulator, pneumatic system and ABS sensors. Installed air pressure gauges, to monitor the pressure in the brake circuit of each wheel. Simulation of blocking (slipping) wheel in the drive mode allows to monitor ABS system demonstration. Installed pressure gauges monitor brake force distribution.

The training board has an integrated ISO type diagnostic connector that allows to connect with the diagnostic tool and perform various measurements, tests and other diagnostic procedures such as reading fault codes, displaying the operating systems parameters, reprogramming and other.

## Technical specifications and functions

- Clearly visible fully functional truck trailers braking system and its components
- Pneumatic braking system without with calipers and heavy hardware, just the most important components of pneumatic and electronical systems
- Functional electronic EBS system
- Installed pressure gauges monitor the pressure in the brake circuit of each wheel
- Driving mode simulation
- The training stand can be used for mechanical service and repair training
- Integrated emergency stop button
- On board 24V, Compressed air connection

## Control unit diagnosis

- Diagnosis of electronic WABCO EBS D 2S/2M system through ISO type diagnostic connector
- Electronic control unit (ECU) identification
- Reading/erasing fault codes
- Displaying the operating system parameters (live data)
- Reprograming possibility

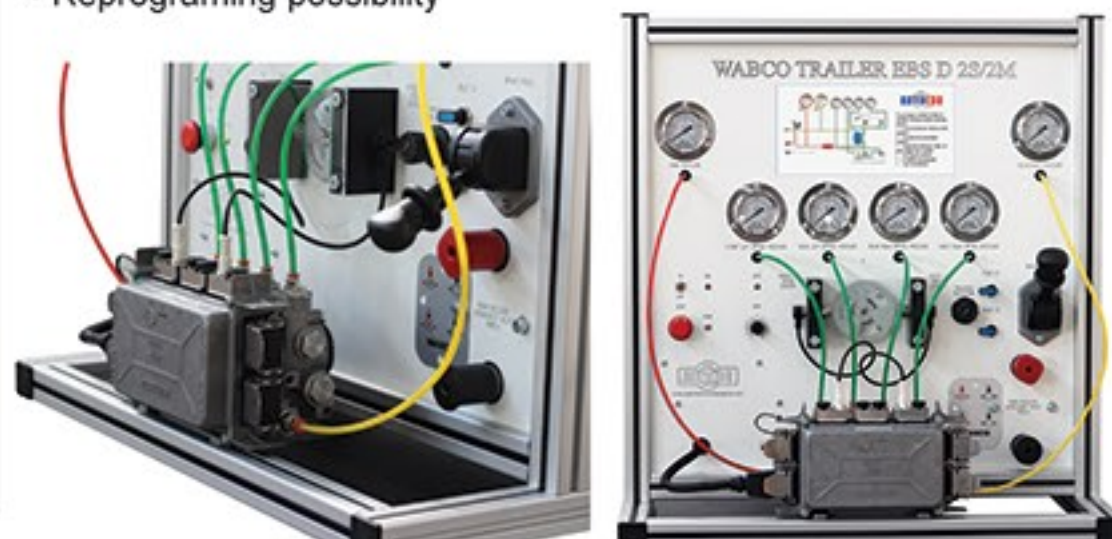

Order No.: MSPS EBS D

Changes reserved!



# EDUCATIONAL DIESEL ENGINE MODEL WITH CR EDC – 15 FUEL SUPPLY SYSTEM

Self – contained, fully operational diesel engine model is installed in a mobile frame. This training engine is specially designed to demonstrate Common Rail diesel injection system and operational structure. The educational training engine is based on Renault original (refurbished) components with functional engine control system Bosch EDC 15.

The training engine is a great educational tool that allows students to learn the structure of the engine and its components, power supply system, cooling system, engine control system. It also allows to study components and operation modes of the engine control system, perform various measurements, tests and other diagnostic procedures.

## Technical specifications and functions

- The educational functional engine model with CR fuel supply system, instrument cluster, cooling system, power supply system and the exhaust system
- Completed with safety removable panels to protect against hot and rotating parts
- Electric wiring diagram with built – in banana plug jumpers for measurements and simulation of system fault codes;
- Ability to simulate more than 20 faults by disconnecting Banana plug jumpers
- Engine with external components is clearly visible after removing safety panels. Easy access to the engine and its components for service and maintenance
- Integrated engine emergency stop button

## Diagnostic and measurement

### Oscilloscope/multimeter

- System's parameters are measured by connecting to the banana connector
- Ability to measure electrical signal parameters of each system component (such as sensor or actuator)

### Control unit diagnosis

- Diagnosis through OBD 16 – pin diagnostic connector
- Electronic control unit (ECU) identification
- Reading/erasing fault codes
- Displaying the operating system parameters (live data)
- Activating the actuators (depends on the control unit)
- Throttle adaptation
- Control unit coding/configuration

### Other

- The stand has a closed structure – internal wiring is not visible; Instrument cluster, measurement and fault simulation panel is integrated in a closed aluminum frame construction;
- Dimensions approx.: (HxLxW) 1550x1000x1200mm
- Nett weight approx.: 350 Kg
- Made in Lithuania
- CE certificate

### Optional accessories

- Vacuum gauge
- Low pressure gauge in the fuel supply line
- Automotive oscilloscope
- OBD diagnostic scan tool
- Diesel smoke meter
- The exhaust extraction system

Order No.: MVCR 1

Changes reserved!





# EDUCATIONAL WORKING ENGINE MODEL WITH (TSI) DIRECT PETROL INJECTION

Self – contained, fully operational engine is installed in a mobile frame. This training engine with direct petrol injection (TSI) system is specially designed to demonstrate the engine management system and operational structure. The educational training engine is based on Audi/VW original (refurbished) components with MOTRONIC MED 17.5.5 engine management system.

The training engine is a great educational tool that allows students to learn the structure of the engine and its components, power supply system, cooling system, engine control system, turbocharger. It also allows to study components and operation modes of the engine control system, perform various measurements, tests and other diagnostic procedures.

## Technical specifications and functions

- The educational functional engine model with direct petrol injection (TSI) system, instrument cluster, cooling system, power supply system, turbocharger and the exhaust system
- Ability to measure the exhaust gas before and after the catalytic converter
- Completed with safety removable panels to protect against hot and rotating parts
- Electric wiring diagram with built – in banana plug jumpers for measurements and simulation of system fault codes;
- Ability to simulate more than 30 faults by disconnecting Banana plug jumpers
- The engine with external components is clearly visible after removing safety panels. Easy access to the engine and its components for service and maintenance
- Integrated engine emergency stop button

## Diagnostic and measurement

### Oscilloscope/multimeter

- System's parameters are measured by connecting to the banana connector
- Ability to measure electrical signal parameters of each system component (such as sensor or actuator)
- Ability to measure high voltage circuit of the ignition system

### Control unit diagnosis

- Diagnosis through OBD 16 – pin diagnostic connector
- Electronic control unit (ECU) identification
- Reading/erasing fault codes
- Displaying the operating system parameters (live data)
- Actuator test (depends on the control unit)
- Throttle adaptation
- Control unit coding/configuration

### Other

- The stand has a closed structure – internal wiring is not visible; Instrument cluster, measurement and fault simulation panel is integrated in a closed aluminum frame construction;
- Dimensions approx.: (HxLxW) 1550x1000x1200 mm
- Nett weight approx.: 300 Kg
- Made in Lithuania
- CE certificate

### Optional accessories

- Examination console for 10 hidden fault simulations
- Vacuum gauge
- The pressure gauge in the fuel supply line
- Automotive oscilloscope
- OBD diagnostic scan tool
- The gas analyzer
- The exhaust extraction system



Changes reserved!

Order No.: MVTSI 1



# EDUCATIONAL ENGINE MODEL WITH (MPI) PETROL INJECTION SYSTEM

Self – contained, fully operational engine is installed in a mobile frame. This training engine with multipoint petrol injection (MPI) system MOTRONIC is specially designed to demonstrate the engine management system and operational structure. The educational training engine is based on Audi/VW original (refurbished) components.

The training engine is a great educational tool that allows students to learn the structure of the engine and its components, power supply system, cooling system, engine control system. It also allows to study components and operation modes of the engine control system, perform various measurements, tests and other diagnostic procedures.

## Technical specifications and functions

- The educational functional engine model with fuel supply system, instrument cluster, cooling system, power supply system and exhaust system
- Ability to measure the exhaust gas before and after the catalytic converter
- Completed with safety removable panels to protect against hot and rotating parts
- Electric wiring diagram with built in banana plug jumpers for measurements and simulation of system fault codes;
- Ability to simulate more than 20 faults by disconnecting Banana plug jumpers
- Engine with external components is clearly visible after removing safety panels. Easy access to the engine and its components for service and maintenance
- Integrated engine emergency stop button

## Diagnostic and measurement

### Oscilloscope/multimeter

- System's parameters are measured by connecting to the banana connector
- Ability to measure electrical signal parameters of each system component (such as sensor or actuator)
- Ability to measure high voltage circuit of the ignition system

### Control unit diagnosis

- Diagnosis through OBD 16 – pin diagnostic connector
- Electronic control unit (ECU) identification
- Reading/erasing fault codes
- Displaying the operating system parameters (live data)
- Actuator test (depends on the control unit)
- Throttle adaptation
- Control unit coding/configuration

### Other

- The stand has a closed structure – internal wiring is not visible; Instrument cluster, measurement and fault simulation panel is integrated in a closed aluminum frame construction
- Dimensions approx.: (HxLxW) 1550x1000x1200mm
- Nett weight approx.: 310 Kg
- Made in Lithuania
- CE certificate

### Optional accessories

- Vacuum gauge
- The fuel pressure gauge in the fuel supply line
- Automotive oscilloscope
- OBD diagnostic scan tool
- The gas analyzer
- The exhaust extraction system

Order No.: MVMPI 1

Changes reserved!





# EDUCATIONAL PETROL/ELECTRIC HYBRID TECHNOLOGY WORKING ENGINE

Fully operational hybrid electric system with petrol internal combustion engine mounted in a mobile frame. The hybrid system is designed to demonstrate the internal combustion engine, electric motor, gearbox and structure of the rechargeable energy storage system. The educational training engine is based on Toyota original (refurbished) engine.

The training engine model with functional petrol/electric hybrid powertrain is a great educational tool that allows students to learn the components of the hybrid system, power supply system, rechargeable energy storage system and cooling system. It also allows to study components and operation modes of the engine, perform various measurements, tests and other diagnostic procedures.

## Technical specifications and functions

- The educational functional engine with petrol/electric TOYOTA HYBRID CONTROL SYSTEM – II (THS-II), automatic gearbox, climate control system, instrument cluster, cooling system, electric power supply system, CAN gateway network, the exhaust system and etc.
- Electrical wiring diagram with built - in banana plug jumpers for measurements and simulation of the system fault codes;
- Ability to simulate more than 50 faults by disconnecting Banana plug jumpers
- Ability to measure the exhaust gas before and after the catalytic converter
- Completed with safety removable panels to protect against hot and rotating parts
- The engine with external components is clearly visible after removing safety panels. Easy access to the engine and its components for service and maintenance
- Fully functioning automatic climate control system with all most important components like electric AC compressor, R134a refrigerant, service couplers and etc.
- Integrated emergency stop button

## Diagnostic and measurement

### Oscilloscope/multimeter

- System's parameters are measured by connecting to the banana plug jumpers
- Ability to measure electrical signal parameters of each system component (such as sensor or actuator)

### Control unit diagnosis

- Diagnosis through OBD (J1962) 16 – pin diagnostic connector
- Electronic control unit (ECU) identification
- Reading/erasing fault codes
- Displaying the operating system parameters (live data)
- Actuator test (depends on the control unit)
- Control unit coding/configuration

The working engine model contains these ECU's which could be found and readout with the scan tool:

- Hybrid Control System ECU
- Power Source ECU
- Engine ECU
- Transmission Control ECU
- Hybrid Vehicle Battery ECU
- AC Climate Control ECU
- Gateway ECU
- Transponder Key ECU
- Combination Meter ECU

Order No.: MVHY1

Changes reserved!

### Other

- The stand has a closed structure – internal wiring is not visible; Instrument cluster, measurement and fault simulation panel is integrated in a closed aluminum frame construction;
- Dimensions approx.: (HxLxW) 1750x1450x1200mm
- Nett weight approx.: 470 Kg
- Made in Lithuania
- CE certificate

### Optional accessories

- Vacuum gauge
- The pressure gauge in the fuel supply line
- Automotive oscilloscope
- OBD Diagnostic scan tool
- The gas analyzer
- The exhaust extraction system
- Air Conditioning service station

According to customer's request there is a possibility to manufacture car or truck (petrol or diesel) working engine model!

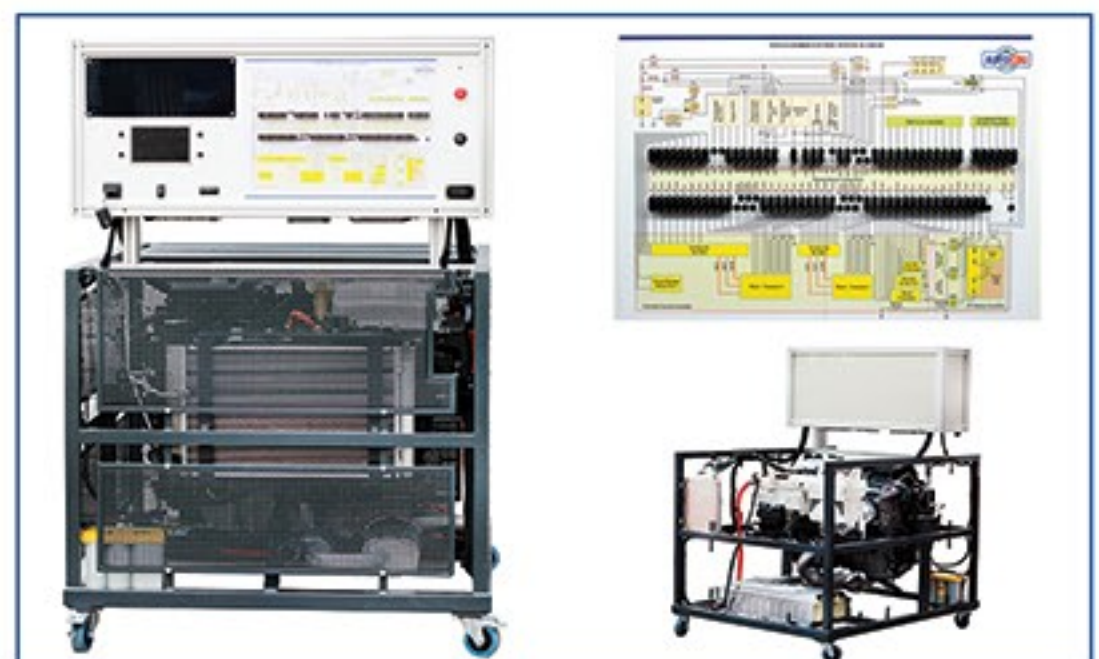



# EDUCATIONAL TRUCK ENGINE MODEL WITH THE PUMP - LINE - NOZZLE (PLD) FUEL SUPPLY SYSTEM

Self – contained, fully operational truck diesel engine is installed in a mobile frame. This training truck engine is specially designed to demonstrate the pump-line-nozzle diesel injection system and operational structure. The educational training truck engine is based on Mercedes ATEGO original (refurbished) components with functional engine control system.

The training truck engine is a great educational tool that allows students to learn the structure of engine and its components, power supply system, cooling system, engine control system. It also allows to study components and operation modes of the engine control system, perform various measurements, tests and other diagnostic procedures.

## Technical specifications and functions

- The educational functional engine model with PLD fuel supply system, instrument cluster, cooling system, power supply system and exhaust system
- Completed with safety removable panels to protect against hot and rotating parts
- Electric wiring diagram with built – in banana plug jumpers for measurements and simulation of system fault codes
- Ability to simulate more than 10 faults by disconnecting Banana plug jumpers
- Engine with external components is clearly visible after removing safety panels. Easy access to the engine and its components for service and maintenance
- Integrated engine emergency stop button

## Diagnostic and measurement

### Oscilloscope/multimeter

- System's parameters are measured by connecting to the banana connector
- Ability to measure electrical signal parameters of each system component (such as sensor or actuator)

### Control unit diagnosis

- Diagnosis through pin diagnostic connector
- Electronic control unit (ECU) identification
- Reading/erasing fault codes
- Displaying the operating system parameters (live data)
- Activating the actuators (depends on the control unit)
- Control unit coding/configuration

### Other

- The stand has a closed structure – internal wiring is not visible; Instrument cluster, measurement and fault simulation panel is integrated in a closed aluminum frame construction;
- Dimensions approx.: (HxLxW) 1900x2600x1100mm
- Nett weight approx.: 950 Kg
- Gross weight approx.: 1200 Kg
- Made in Lithuania
- CE certificate

### Optional accessories

- Examination console for 10 hidden fault simulations
- Automotive oscilloscope
- OBD diagnostic scan tool
- Diesel smoke meter
- The exhaust extraction system

According to customer's request there is a possibility to manufacture car or truck (petrol or diesel) working engine model!

Order No.: MV SPLD 1

Changes reserved!

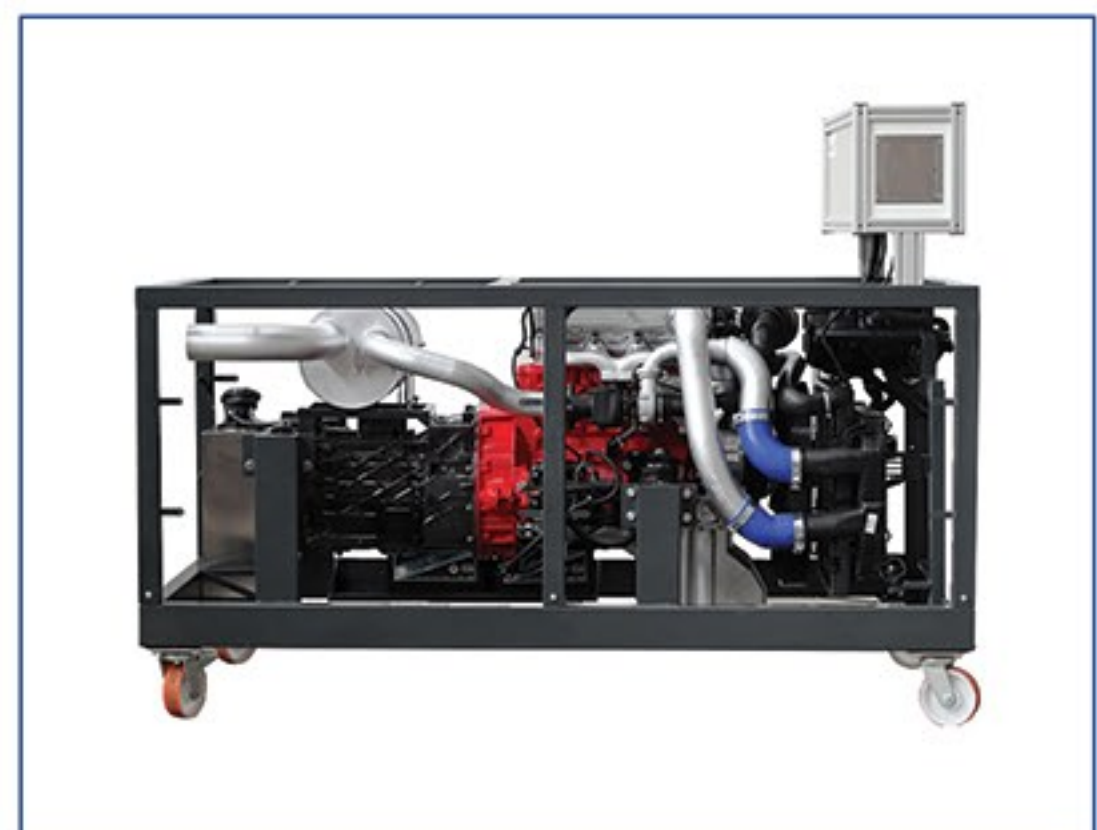



# PETROL/ELECTRIC HYBRID TECHNOLOGY FUNCTIONAL MODEL

The educational fully operational functional model with hybrid petrol / electric system. This functional model is as an alternative for a complete vehicle, just in space saving version, and it has the same advantages of a complete car. The functional model made from Toyota Prius II, by separation of body just after the B-pillars. In the front end all the components like engine air conditioning system and other components remain fully functional.

The functional model remains mobile with the help of additional swivel casters. This functional model is a great educational tool that allows students to learn the components of the hybrid system, air conditioning system, ABS / ESP system, SRS AIRBAG system and other systems and its components, operation modes, various measurements, tests and other diagnostic procedures.

## Technical specifications and functions

The educational functional model with:

- Petrol/electric TOYOTA HYBRID CONTROL SYSTEM – II (THS-II)
- Automatic gearbox
- Climate control
- CAN Gateway network
- Exhaust system
- ABS/ESP system
- SRS Airbag system (Integrated inactive airbag igniters (after activation))

## Diagnostic and measurement

Control unit diagnosis

- Diagnosis through OBD 16 – pin diagnostic connector
- Electronic control unit (ECU) identification
- Reading/erasing fault codes
- Displaying the operating system parameters (live data)
- Actuator test (Depends on the control unit)
- Control unit coding/configuration (depends on the control unit)
- Automatic search of ECU's (depends on scan tools possibility)

Optional accessories

- Built in measuring box with open contacts and wiring diagram for engine control system
- Fault simulation for engine control system
- Built in measuring box with open contacts and wiring diagram for climate control
- Fault simulation for climate control
- Built in measuring box with open contacts and wiring diagram for ABS/ESP
- Fault simulation for ABS/ESP
- Built in measuring box with open contacts and wiring diagram for SRS AIRBAG
- Fault simulation for SRS AIRBAG

Optional tools and equipment for measurement and services:

- Automotive oscilloscope
- OBD Diagnostic scan tool
- The gas analyzer
- The exhaust extraction system
- Air Conditioning service station

Other

- Dimensions approx.: (HxLxW) 1700x2900x1700mm (Standard version PMTP – 01)
- Dimensions approx.: (HxLxW) 1300x2900x1700mm (Without roof version PMTPK – 01)
- Nett weight approx.: 900 Kg;

Changes reserved!



Order No.: PMTP-01



Order No.: PMTPK-01



# AUTOMOTIVE TRAINING EQUIPMENT

## WHEEL ALIGNMENT TRAINER

Wheel alignment training stand is specially designed to demonstrate the vehicle chassis structure and wheel alignment procedures. McPherson-type front suspension and multi-link rear suspension is integrated in a training stand. Wheel alignment training stand is a great educational tool that allows students to introduce the different types of automobile chassis, study suspension components and angles modification, perform various measurements and other diagnostic procedures.

Using this training stand it is very easy to teach several students at the same time, because all suspension components are visible from all sides. Suspension geometry adjustments are performed like in a real automobile – using screws and tools.

### Technical specifications and functions

#### Main functions:

Wheel alignment training stand consists of McPherson-type front suspension and multi-link rear suspension. McPherson-type front suspension has 8 adjustment points that allows:

1. To adjust camber, steering axis inclination (SAI) and caster angles by sliding shock absorber upper mount.
2. To adjust camber at 2 points.
3. To adjust camber, caster and SAI angles by turning front eccentric bolt on the front lever.
4. To adjust caster angle by turning rear eccentric bolt on the front lever. By turning the front and rear eccentric bolts it is possible to adjust camber.
5. To adjust Toe by the steering tie rod.
6. To adjust camber angle by sliding the wheel with unscrewed lower link on the front lever. Steering axis inclination is also changing.
7. Caster angle and automobile base can be adjusted by loosening the subframe and sliding it along the length. Camber angle and steering axis (SAI) of the vehicle can be adjusted by sliding subframe sideways.
8. Steering wheel lock bolt allows to capture the steering wheel and the steering column in order to keep the steering wheel in a stable position.

The rear multi-link suspension has 3 adjustment points, that allows:

1. To adjust Toe angles (alignment) by adjusting lower rod
2. To adjust camber angles (alignment) by adjusting the eccentric bolts on the upper lever
3. To adjust the longitudinal position (Wheel base) of the wheel by adjusting the front rod of the rear suspension

### Diagnostic and measurement

\* With the wheel aligner for the suspension geometry adjustment it is possible to demonstrate these measurements and settings:

- Wheelbase distances and diagonals
- Axis shift in relation to one another
- Scrub radius, Caster trail
- Steering axis inclination (SAI)
- Tread width, Wheel base length
- Front and rear axle wheel set back
- Ride height (zero ride height)
- Central line position
- Traction line operation, thrust angle
- Toe difference angle
- Turning radius (Rolling radius)
- Other

Order No.: MSVAZ 1

Changes reserved!

#### \* Depending on wheel aligner software possibilities

Wheel alignment training stand is designed for making demonstrations of the suspension angles by using all types and technology of wheel aligners:

- 3D Technology Wheel Aligner
- CCD Technology Wheel Aligner
- Mechanical Wheel Aligner (Rulers, ropes, lasers, and etc.)

*The best and most suitable wheel aligner is with 3D technology. The car lift is not necessary for training and demonstration because an open construction of the training stand construction allows to see and perform various measurements from all sides.*

#### Other

- Wheel alignment training stand can be easily folded and placed so that it take up minimal space for storage and transportation
- The front axle has hydraulic brakes
- The rear axle wheels can be blocked by locking bolts
- Dimensions approx. (HxLxW): Fully spread base 110 x 310 x 170 / Folded for storage 110x 165 x 170 (Standing stand on the wheels) / Folded for storage 165 x 110 x 170 (Upright stand)
- Nett weight approx.: 195 Kg
- Made in Lithuania
- CE certificate

#### Optional accessories

- Wheel aligner
- 4 post lift for wheel alignment
- Scissor lift for wheel alignment





# PETROL ENGINE CUTAWAY MODEL DOHC FSI TIMING BELT REPLACEMENT

The educational training engine model is based on original components of the vehicle. This cutaway model coloured in different colors in order various parts and cross-sections could be easier differentiated.

## Educational purpose of the engine model

- Demonstration of the different components of the engine
- Demonstration of the DOHC timing belt replacement using special tools
- Demonstration of the alternator belt replacement
- Demonstration and explanation of the technical literature/schemes and procedures
- Demonstration of the DOHC engine with direct fuel injection (FSI) combustion chamber

The training engine cutaway model is a great educational tool that allows students to learn the structure of the engine and its components, operation modes and maintenance, technical specifications, special tools and their use.

## Technical specifications and functions

### Visible components of the sectioned engine model:

- Engine block
- Engine head
- Crankshaft
- Connecting rod
- DOHC dual overhead camshaft (camshafts, valves, valve lifters, water pump and etc.)
- Pistons with rings
- Timing belt with camshaft sprocket and tensioners;
- Alternator belt with tensioner

### Cutaway engine model is designed to demonstrate:

- Piston, rings, combustion chamber, intake and exhaust ports, DOHC components, injector and glow plug positions in a combustion chamber
- Operation of the DOHC mechanism by turning the crankshaft\*

*\*Training cut away engine model is not suitable for intensive rotation. All rotating parts must be lubricated before the rotation.*

### Timing and alternator belt replacement

The educational engine model contains all elements of the original car: timing belt, tensioners, alternator belt, crankshaft sprocket and etc. Using instructions and recommendations it is possible to demonstrate belt replacement procedures. Torque measurements of the components can be performed by using special tools.

### Other

- Minimal space for training and storage
- Minimal weight in order to avoid additional transportation or mounting stands. Demonstrations can be performed using workbench or tool trolley
- Cross-section of the training engine is protected with safety plastic protection
- The training engine model is equipped with bench clamps
- The training engine model is equipped with special tool kit for timing belt replacement

Order No.: IVDB01

Changes reserved!

### Other

- Dimensions (height x length x width ) 500x500x300mm
- Nett weight approx.: 40 Kg
- Made in Lithuania

### Optional accessories

- Standard tool kit
- Workbench
- Technical car database

According to customer's request there is a possibility to manufacture car or truck (petrol or diesel) working engine model!

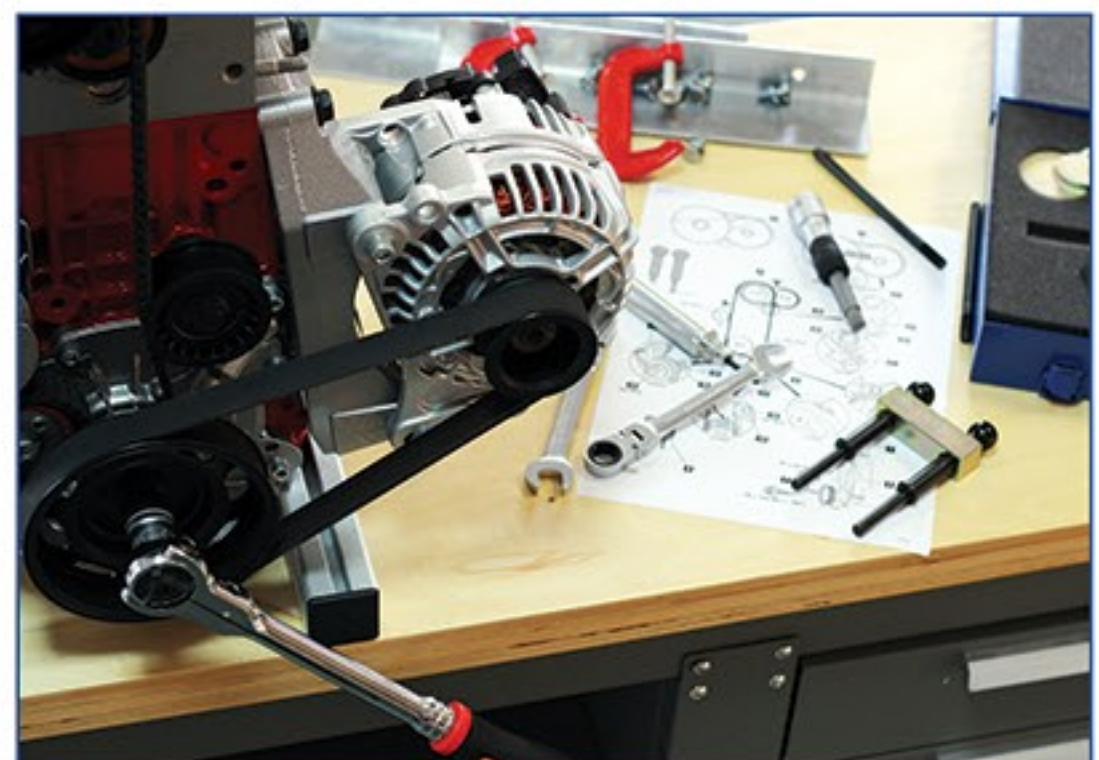



# PETROL DOHC ENGINE CUTAWAY MODEL DOHC MPI TIMING CHAIN REPLACEMENT

The educational cutaway engine model is based on original components of the vehicle. This cutaway model is coloured in different colours in order various parts and cross-sections could be easier differentiated.

Educational purpose of this cutaway model (engine stand):

- Demonstration of the different components of the engine
- Demonstration of the DOHC timing chain replacement
- Demonstration of the alternator belt replacement
- Demonstration using special tools for timing chain replacement
- Demonstration and explanation of the technical literature/schemes and procedures
- Demonstration of the DOHC engine with multipoint fuel injection (MPI) combustion chamber

The training engine cutaway model is a great educational tool that allows students to learn the structure of the engine and its components, operation principles and maintenance techniques, technical specifications, special tools and their use.

## Technical specifications and functions

Visible components of the sectioned engine model:

- Engine block
- Engine head
- Crankshaft
- Connecting rod
- DOHC dual overhead camshaft (camshafts, valves, valve lifters, water pump and etc.)
- Pistons with rings
- Timing chain with camshaft sprocket and tensioners, oil pump
- Alternator belt with tensioner

## Cutaway engine model is designed to demonstrate:

- Piston, rings, combustion chamber, intake and exhaust ports, DOHC components, injector and glow plug positions in a combustion chamber
- Operation of the DOHC mechanism by turning the crankshaft\*

NOTE: \*Training cut away engine model is not suitable for intensive rotation. All rotating parts must be lubricated before the rotation.

## Timing chain and alternator belt replacement

The educational cutaway engine model contains all elements of the original car: timing chain, tensioners, alternator belt, crankshaft sprocket and etc. Using instructions and recommendations it is possible to demonstrate chain replacement procedures. Torque measurements of the components can be performed by using special tools.

### Other

- Minimal space for training and storage
- Minimal weight in order to avoid additional transportation or mounting stands. Demonstrations can be performed on any workbench or tool trolley.
- Cross-section of the training engine is protected with safety plastic protection

Order No.: IVDB02

Changes reserved!

### Other

- The training engine model is equipped with fasteners
- Dimensions (height x length x width) 750x670x440mm
- Nett weight approx.: 81 Kg
- Made in Lithuania

### Optional accessories

- Standard tool kit
- Workbench
- Technical car database

According to customer needs there is a possibility to manufacture a truck or a car, petrol or diesel cutaway engine model!

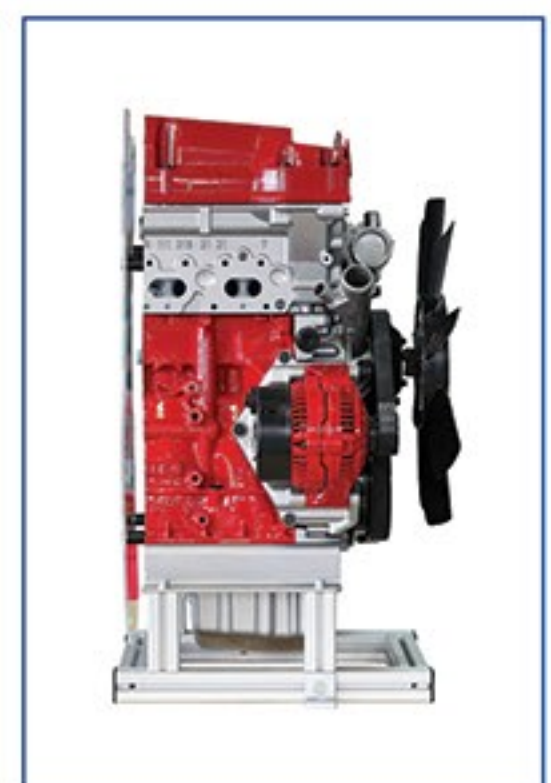
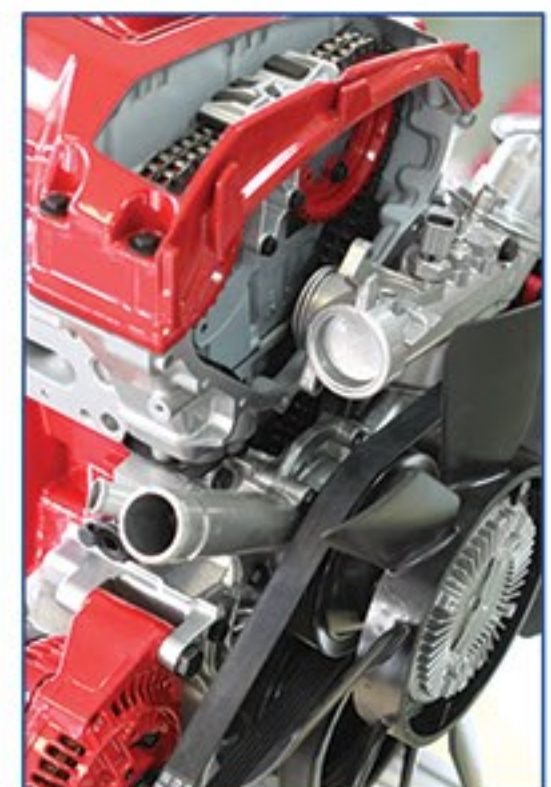



# DIESEL OHC COMMON RAIL ENGINE CUTAWAY MODEL TIMING BELT REPLACEMENT

The educational training engine model is based on original components of the vehicle. This cutaway model is coloured in different colours in order various parts and cross-sections could be easier differentiated.

## Educational purpose of the engine model

- Demonstration of the different components of the engine;
- Demonstration of the OHC timing belt replacement using special tools;
- Demonstration of the alternator belt replacement;
- Demonstration and explanation of the technical literature/diagrams and procedures;
- Demonstration of the OHC engine with Diesel Common Rail injection (CR) combustion chamber;

The training engine cut away model is a great educational tool that allows students to learn the structure of the engine and its components, operation modes and maintenance, technical specifications, special tools and their use.

## Technical specifications and functions

### Visible components of the sectioned engine model:

- Engine block
- Engine head
- Crankshaft
- OHC camshaft with valves
- Pistons with rings
- Timing belt with camshaft sprocket and tensioners
- Alternator belt with tensioner
- High pressure CR pump
- Power steering pump
- Air conditioner compressor

### Cut away engine model is designed to demonstrate:

- Piston, rings, combustion chamber, intake and exhaust ports, OHC components, injector and glow plug positions in a combustion chamber;
- Operation of the OHC mechanism by turning the crankshaft\*;

*\*Training cut away engine model is not suitable for intensive rotation. All rotating parts must be lubricated before the rotation.*

### Timing and alternator belt replacement

The educational engine model contains all elements of the original car: timing belt, tensioners, alternator belt, crankshaft sprocket and etc. Using instructions and recommendations it is possible to demonstrate belt replacement procedures. Torque measurements of the components can be performed by using special tools.

### Other

- Minimal space for training and storage;
- Minimal weight in order to avoid additional transportation or mounting stands. Demonstrations can be performed using workbench or tool trolley;

### Other

- Cross-section of the training engine is protected with safety plastic protection;
- The training engine model is equipped with bench clamps;
- The training engine model is equipped with special tool kit for timing belt replacement;
- Dimensions (height x length x width ) 650x600x320mm;
- Nett weight approx.: 75 Kg; • Made in Lithuania

### Optional accessories

- Standard tool kit
- Workbench
- Technical car database

According to customer's request there is a possibility to manufacture car or truck (petrol or diesel) working engine model!

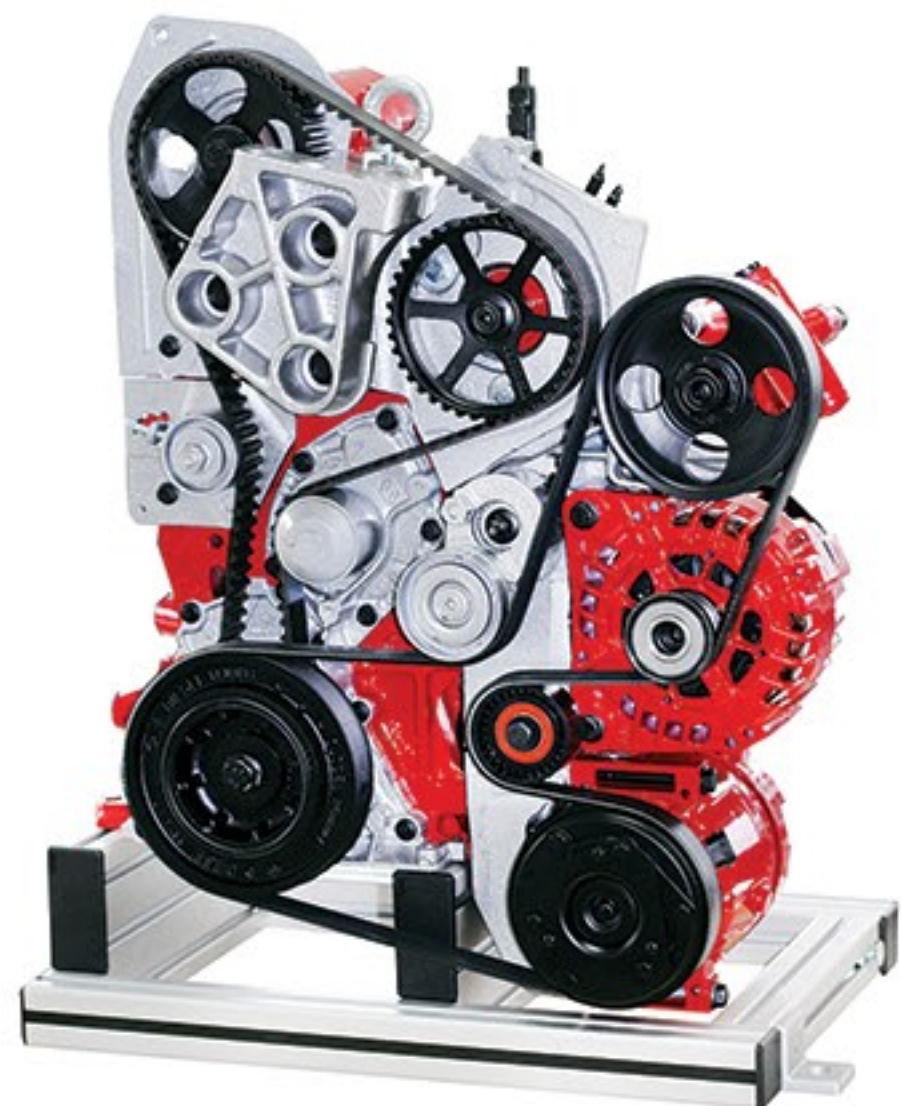

Order No.: IVOD –CR01

Changes reserved!



# DIESEL DOHC COMMON RAIL ENGINE CUTAWAY MODEL TIMING CHAIN REPLACEMENT

Educational training engine model is based on original components of the vehicle. This cutaway model is coloured in different colours in order various parts and cross-sections could be easier differentiated.

## Educational purpose of the training stand

- Demonstration of the different components of the engine
- Demonstration of the different components of the engine
- Demonstration of the DOHC timing chain replacement
- Demonstration of the alternator belt replacement
- Demonstration using special tools for timing chain replacement
- Demonstration and explanation of the technical literature/schemes and procedures
- Demonstration of the engine with direct fuel injection (CR) and DOHC mechanism
- Demonstration of the engine oil pump and lubrication system

*Training engine cutaway model is a great educational tool that allows students to learn the structure of the engine and its components, operation modes and maintenance techniques, technical specifications, special tools and their use.*

## Technical specifications and functions

### Visible components of the engine cutaway model:

- Engine block
- Engine head
- Crankshaft
- Connecting rod
- DOHC dual overhead camshaft (camshafts, valves, water pump and etc.)
- Pistons with rings
- Timing chain with camshaft sprocket and tensioners
- Alternator belt with tensioner
- Air conditioning compressor
- High pressure CR pump

### Cut away engine model is designed to demonstrate:

- Piston, rings, combustion chamber, intake and exhaust ports, DOHC components, injector and glow plug holes in a combustion chamber
- Operation of the DOHC mechanism by turning the crankshaft\*

*\*Training cut away engine model is not suitable for intensive rotation. All rotating parts must be oiled before the rotation.*

### Timing chain and alternator belt replacement:

Educational cutaway engine model contains all elements of the original car: timing chain, tensioners, alternator belt, crankshaft sprocket and etc. Using instructions and recommendations it is possible to demonstrate belt replacement procedures. Torque moments of the elements can be performed by using special tools.

Order No.: IVDD-CR02

Changes reserved!

### Other

- Minimal space for training and storage
- Minimal weight in order to avoid additional transportation or mounting stands. Demonstrations can be performed using workbench or tool trolley
- Cross-section of the training engine is protected with safety plastic protection
- Training engine model is equipped with fasteners
- Dimensions (height x length x width ) 600 x 500 x 300 mm
- Weight (netto) approx.: 75 Kg
- Made in Lithuania

### Optional accessories

- Standard tool kit
- Workbench
- Technical web based car database AUTODATA

*According to customer needs there is a possibility to manufacture a truck or car, the petrol or diesel cut away engine model!*

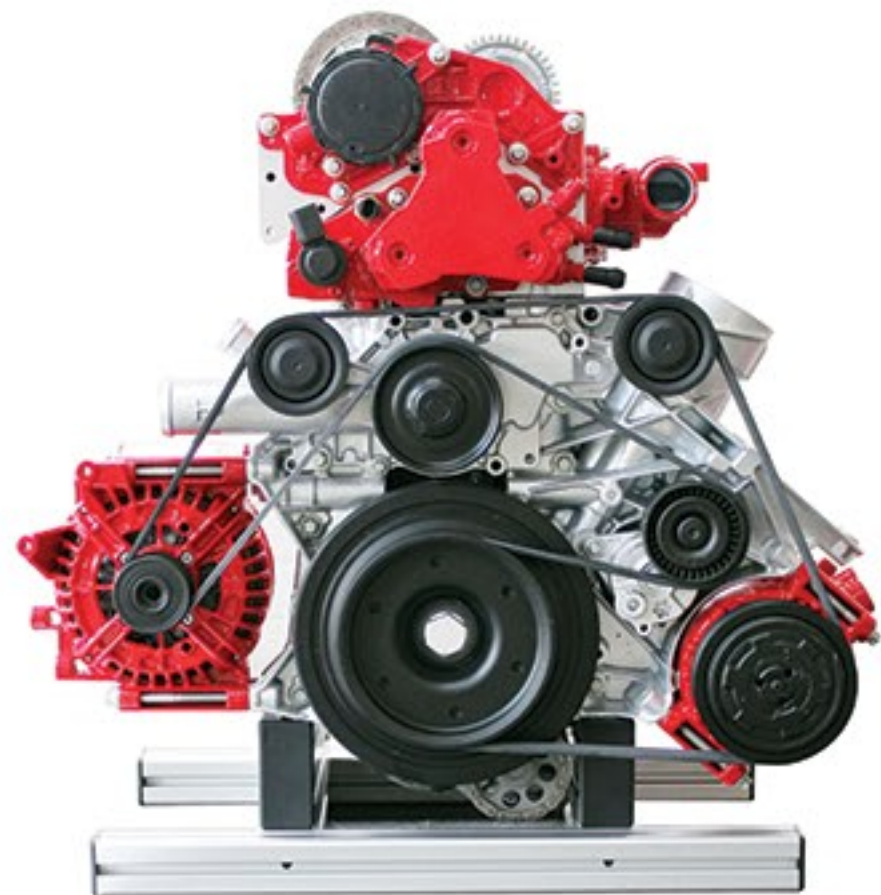



# ELECTUDE GAME-BASED LEARNING

## Game – based learning

- Provides a groundbreaking, cutting edge automotive e-learning curriculum
- Utilises gaming technology to engage, motivate, excite and retain learners
- Introduces and develops critical thinking and decision making, stem principles, as well as automotive diagnostic skills and training
- Gives instructors everything needed to create, teach, track & test students
- Has a proven track record with thousand of customers in over 50 countries
- May be used from any location, any time and on almost any online device

## What is Electude?

Electude is the creator of the world's leading automotive e-learning solution that is used by thousands of schools, companies and governmental organisations in over 50 countries.

Founded in 1990 by two automotive instructors who pioneered a new and unprecedented approach to automotive education. The Electude team's vision led to the creation of solutions which provide a unique and effective tool to teach all automotive learners by making it interactive, engaging, highly efficient and fun through the use of gaming technology.



## What Electude can offer?

Electude offers simulation-based, e-learning lessons. Students are attracted by Electude's unique 3D gamification learning environment. This discovery-based method is about „learning by doing“.

Electude is a cloud based automotive e-learning solution that allows instructors to assign, create, manage and grade lessons, exercises, tests and tasks. Students can complete their assignments from any location and from almost any online device.



Automatic transmission

## Why Electude?

- Created specifically for automotive learners
- Makes learning dynamic, effective, fast and much more fun.
- Completely aligned to NATEF, Lernfelder, IMI, City & Guilds, Europe areas and requirements
- As technology changes, „Electude“ adapts real time.
- More cost effective than textbooks
- The Electude Simulator allows for virtual fault-finding exercises
- Online courses for instructors that count for Continued Professional Development hours

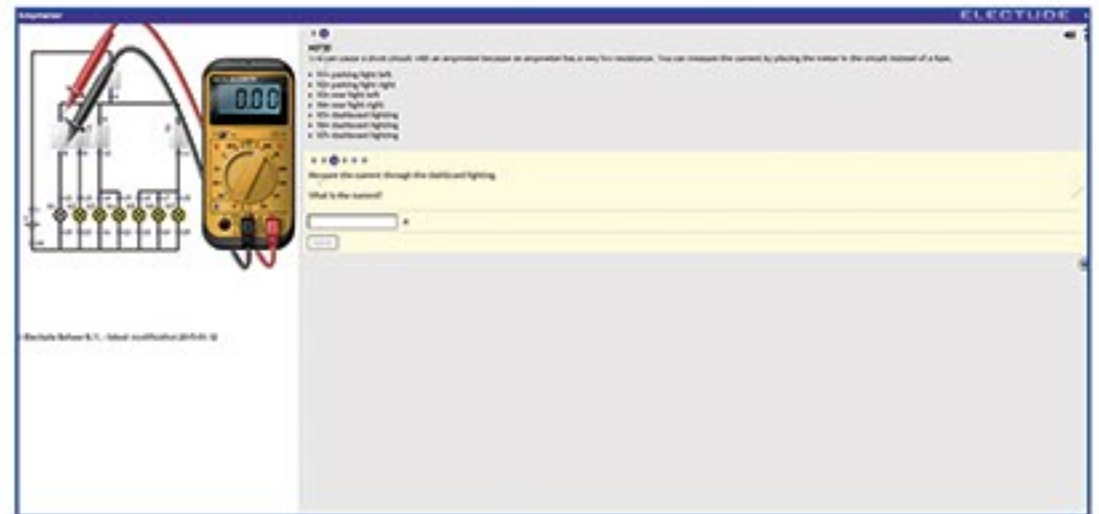

Tasks with a multimeter



The structure of the alternator

## Learning designed for automotive students & trainees

The Electude online curriculum consists of hundreds of interactive lessons that are designed specifically for instructing today's generation of automotive learners. Electude is replacing traditional textbooks with its innovative and effective approach to learning:

- Over 1,000 state-of-the-art interactive lessons, tests and simulations, 2-3 new module lessons added or updated weekly at no extra charge.
- Learning management system that allows results tracking, testing and customising classes & courses.
- The brand new Electude Simulator – Engine Management.
- IMI and City & Guilds compliant.
- Pre- and post-tests per subject.
- Loved by students because it is based on gaming principles.
- Budget friendly, with a range of affordable pricing options.





# ELECTUDE GAME-BASED LEARNING

## Discovery-based learning

In order to improve learning retention and understanding, the lessons have been developed by Electude's authors and game designers based on the educational principle of Guided Seld Discovery. With small interactive tasks, students are guided stepby- step through a discovery-based learning process.

## ASE CASE accredited training

All Electude trainers can undergo the ASE CASE (the leading automotive training quality standard used in the United States) accredited Electude Skills Training at no additional charge. This training will allow the participants to master the Electude automotive e-learning solutions.

## Main facts and numbers

- Customers in over 50 countries
- Over 200,000 users
- Over 20,000 instructors & teachers
- Over 2,000 customers
- Available in over 30 languages

## How Electude associated with AutoEDU?

- AutoEDU and Electude are complementary products for automotive students
- Students with AutoEDU training equipment can perform the practical tasks and use gained skills in a virtual Electude environment
- AutoEDU training stands allow students to study the real automobile components and processes in the automotive electrical circuits and electronic systems, also, help them to check the learned lectures
- AutoEDU electronic system simulators allow to use both training systems – game-based Electude and the real component-based automotive training equipment for measurement, diagnosis and practical work



Manual transmission



FSI petrol direct injection system



Automatic transmission operating principles



Accredited Training Provider

# ELECTUDE



## OTHER EQUIPMENT

All our manufactured automotive training equipment: working engine models, training boards - simulators of cars and trucks are compatible and could be supplied together with different diagnostic equipment for reading fault codes, live data parameters, activation tests through 16 pole OBD diagnostic connectors or for measurements with multimeter or oscilloscope via pinout facilities. Wheel alignment training stand can be delivered together with the wheel alignment system and different type of car lift. Cutaway engine models can be supplied with different timing or special tools.

AutoEDU manufactures automotive training equipment according to the customer needs, technology or training program. Also, AutoEDU offers a virtual „e-learning“ programs, ability to equip a training class with an educational equipment , teaching material – theoretical and practical for the teachers and examinational tasks and tests for the students. All manufactured equipment can be offered with different diagnostic and measurement equipment, garage equipment and hand tools. If later there is a need, AutoEDU personnel consults, trains, updates, services and repairs supplied educational equipment. Our company can offer a broad range of hand tools, various garage, diagnostic and measurement equipment.



### Diagnostics, oscilloscopes, gas analyzers

Our company can offer partners produced a professional garage, workshop, welding and metal processing equipment and tools.

Diagnostic and other measuring equipment is compatible with AutoEDU educational equipment and complement each other. Automotive diagnostic equipment can be used to scan the ECU information of the educational equipment. Depending on the ECU with a scanner or a device for self-diagnosis there is ability to read and erase fault codes, display the operating system parameters, activating the actuators and perform coding or configuration functions, if they are supported by the ECU.

Oscilloscope is a very important measurement equipment in a learning process. AutoEDU training boards are made so that would be easy to perform measurements of each component at any time without damaging connections. Almost all AutoEDU training boards are available with open contacts so that would be easy connect and perform measurements with two or four channel oscilloscope.

All AutoEDU working petrol engine models have ability to measure the exhaust gas before and after catalytic converter. Using the gas analyzer there is a great opportunity to demonstrate the processes occurring in the vehicle exhaust system. The gas analysis equipment can also be used with AutoEDU educational working diesel engine models.



### Air conditioning recharge equipment

Air conditioning recharge and servicing equipment helps to perform demonstrations with air conditioning and climate control system training board or with Toyota Petrol/Electric Hybrid technology functional models where is an integral part of the air-conditioning system with an electric compressor.

Air conditioning recharge station provides an ability to demonstrate the recharging procedures in a training classroom or service center in real terms.





# OTHER EQUIPMENT

## Tyre changer and wheel balancer equipment

Tyre changer is an automatic or semi-automatic tyre mounting machine designed for automobiles, light and heavy commercial and agriculture vehicles. Safe and reliable equipment can be delivered together with the additional accessories and other supplies. The wheel balancer machines with modern measuring equipment help to fully complete wheel repair bar for light and heavy commercials vehicles.

Also, we are able to offer another garage equipment that may be used in a training service center. In 2001 our company started its business from diagnostic and garage equipment trade, installation, repair and service. This gained experience allows to offer equipment that would be functional and perfectly compatible with the training process and the mechanic specialty.



## Brake testing stand

Brake testing stand is one of the most important equipment in a training service center for car and commercial vehicle brake maintenance and repair. Although the brakes in modern cars are controlled by electronics, it is necessary to mechanically measure and align brake force for each wheel using brake testing stand.



## Lifts

Training car repair workshops are not imaginable without car lifts that can be different depending on purpose use: 2 post electro-hydraulic or electromechanical lifts, scissor or cylindrical, with different lifting capacities from 2,5T to 25T for commercial vehicles.

We are able to offer lifts for different kind of works you would like to perform in a service center. For example, large scissor lifts are commonly used for wheel alignment procedures. Small scissor lifts provide space saving solution for wheel repair and diagnostic procedures. Two post lifts are the most popular and commonly used for chassis repair procedures.

Many years of experience in installing professional repair service centers allows to complete and submit different types of car lifts and plan them in accordance with their purpose.



## Wheel alignment equipment

Wheel alignment equipment is a great educational tool using it together with AutoEDU wheel alignment training stand. AutoEDU wheel alignment training stand is specially designed to demonstrate the vehicle chassis structure and maximum of the wheel alignment procedures which are difficult to show on a real car. Both the „3D“ and „Prism“ wheel aligners combine two different types of the wheel alignment technology and are perfect for student training.



## Workbenches, tool boxes and tools

We offer a large range of different, well-known in the world manufacturers tools. The tools can be assembled in an ergonomic tool boxes or in a drawers of the workbenches. We can offer hand, electric or special tools. We are able to complete tools by car manufacturers' recommendations, engine or chassis types.

The workbenches can be offered with different surfaces: wood, metal, rubberized or stainless steel and with lockable walls, drawer units or without them.





## OTHER EQUIPMENT

### Exhaust extraction system

Exhaust extraction system is a very important element in a training service center if you are planning to teach students car engine diagnostic and repair, or have an intent to purchase an engine test stand or in any case, when you expect that the ignition of the car will be switched on and active in a training service area. Again, as with other equipment, there are many different solutions – it is possible to supply mobile exhaust extraction system and there is no need to mount it. If there is an intent for further construction and modernization of the workshop area perhaps you should think about the floor-mounted exhaust extraction system. Also, there are other solutions, such as on the ceiling hanging coils, mounted systems on the wall or hanging rail exhaust systems that allow car to move in a workshop area with an exhaust extraction system connected to the cars' exhaust system.



### Compressors and compressed air equipment

Compressed air is very important in a training repair service center. Well-planned and properly equipped with high-quality materials and safe piping system, properly calculated air compressor output and productivity will allow the proper use of the equipment and tools. Improperly designed and equipped system does not allow proper and effective use of the equipment. As a result, our company often consults, selects the necessary equipment that would function perfectly.

Our company is able to offer different efficiency rotary screw and reciprocating air compressors, plastic or aluminum piping systems, filters, condensate separation and lubrication systems.



### Other equipment

Other small workshop equipment may be offered depending on what kind of the working processes will be performed in a training repair center. This equipment is not main, but very important: presses, jacks, workshop engine cranes (rotating engine stands) and other hydraulic or pneumatic equipment and tools.



An educational institution often inquires about welding and metalworking equipment. We are able to offer a wide range of welding equipment, from simple semi-automatic to aluminum welding or plasma cutting equipment, spot welding and etc.



Metalworking equipment – metal lathes from school to professional with a digital display. A wide range of milling, drilling, cutting, bending and grinding equipment allows to offer a complete solution for the workshop or small metal processing bar.



Our company has successfully completed equipment installation projects in a number of educational institutions, workshops or car repair service centers where not only already mentioned equipment was used, but also such equipment as car painting cameras, body repair equipment with electronic measurement systems, engine test stands, that could be used for teaching in the repair service center or workshop.

All the above mentioned equipment and tools have been successfully used in other training institutions and in the training process, so you are welcome to contact our company and our well-qualified personnel will help you to choose, design and install equipment according to your choices or needs. Our company offers consultations and trainings for lecturers or teachers if they only need our help. During more than 10 years with many of them we have become partners and mutual beneficial cooperation has grown into a highly appreciated friendship.

# AUTOEDU



# Training boards - simulators



**Engine control system  
MOTRONIC M 3.8.X (MPI)**

- Fully functional system
- Diagnosis through OBD 16 pole diagnostic socket
- Open contacts for measuring system components and circuits
- Fault code simulations

Order No.:MSMPI1



**Engine control system  
BOSCH MOTRONIC MED 7.5.10 (FSI)**

- Fully functional system
- Diagnosis through OBD 16 pole diagnostic socket
- Open contacts for measuring system components and circuits
- Fault code simulations

Order No.:MSFSI1



**Diesel engine control system  
CR/EDC 15**

- Fully functional system
- Diagnosis through OBD 16 pole diagnostic socket
- Open contacts for measuring system components and circuits
- Fault code simulations

Order No.:MSCR1



**CAN BUS  
Training stand**

- Fully functional system
- Diagnosis through OBD 16 pole diagnostic socket
- Open contacts for measuring system components and circuits
- Fault code simulations

Order No.:MSCAN1



**CAN BUS  
Training dashboard**

- Fully functional system with dashboard
- Diagnosis through OBD 16 pole diagnostic socket
- Open contacts for measuring CAN bus signals
- Activations by sending commands via CAN network

Order No.:MSCAN2



**Anti-Lock Braking system  
BOSCH ABS 5.3 training stand**

- Fully functional system
- Diagnosis through OBD 16 pole diagnostic socket
- Open contacts for measuring system components and circuits
- Fault code simulations

Order No.:MSABS1



**ABS/ASR  
Training stand**

- Fully functional system
- Diagnosis through OBD 16 pole diagnostic socket
- Open contacts for measuring system components and circuits
- Fault code simulations

Order No.:MSABS/ASR1



**SRS BOSCH AB 8.4 (AIRBAG)  
Training stand**

- Fully functional system
- Diagnosis through OBD 16 pole diagnostic socket
- Open contacts for measuring system components and circuits
- Fault code simulations

Order No.:MSSRS1



**SRS SIEMENS III (AIRBAG)  
Training stand**

- Fully functional system
- Diagnosis through OBD 16 pole diagnostic socket
- Open contacts for measuring system components and circuits
- Fault code simulations

Order No.:MSSRS2



# Training boards - simulators



**Lighting  
Training stand**

- Fully functional system
- Open contacts for measuring system components and circuits
- Diagnosis of dashboard through OBD 16 pole diagnostic socket

Order No.:MSAS1



**Sensors and actuators  
Training stand**

- Fully functional system
- Open contacts for measuring system components and circuits
- Real, not simulated signals

Order No.:MSD1



**Air conditioning and climate  
Control trainer**

- Air-conditioning system trainer
- System with an orifice tube
- Electronic climate control system CLIMATRONIC
- Fully functional system with R134a refrigerant
- Diagnosis through OBD 16 pole diagnostic socket
- Open contacts for measuring of system's components and circuits
- Fault code simulations

Order No.:MSC1



**Air conditioning and climate  
control trainer**

- Air-conditioning system trainer
- System with an expansion valve
- Electronic climate control system CLIMATRONIC
- Fully functional system with R134a refrigerant
- Diagnosis through OBD 16 pole diagnostic socket
- Open contacts for measuring of system's components and circuits
- Fault code simulations

Order No.:MSC2



**Ignition system  
Training stand**

- Fully functional system
- 3 different types of systems
- Open contacts for measuring system components and circuits

Order No.:MSUS1



**Dual zone air conditioning and climate  
control trainer with auxiliary heater**

- With auxiliary petrol heating unit
- Electronic climate control system CLIMATRONIC
- Fully functional system with R134a refrigerant
- Diagnosis through OBD 16 pole diagnostic socket
- Open contacts for measuring of system's components and circuits. Fault code simulations.

Order No.:MSC3-B



**Dual zone air conditioning and climate  
control trainer with auxiliary heater**

- With auxiliary diesel heating unit
- Electronic climate control system CLIMATRONIC
- Fully functional system with R134a refrigerant
- Diagnosis through OBD 16 pole diagnostic socket
- Open contacts for measuring of system's components and circuits. Fault code simulations.

Order No.:MSC3-D



**Charging  
System trainer**

- Real automotive components;
- Battery charging/discharging with the alternator;
- Alternator loading simulation;
- Negative terminal fault simulation;
- Adjustable rotation speed of the alternator;
- Information panels with the loading, charging, RPM and voltage, Open contacts for a measurement

Order No.:AE38110E



**Truck trailer WABCO EBS D 2S/2M braking  
system training stand**

- Fully functional Wabco EBS system
- Functional pneumatic system
- Diagnosis through OBD 16 pole diagnostic socket
- Driving simulation
- 6 measuring gauges
- Fault simulation

Order No.:MSPS-EBS-D



# Working engine models



**Educational petrol engine with multipoint injection system (MPI) EURO 3**

- Fully functional system
- Diagnosis through OBD 16 pole diagnostic socket
- Open contacts for measuring system components and circuits
- Fault code simulations

Order No.:MVMP1



**Educational petrol engine with multipoint injection system (MPI) (EURO 4-5)**

- Based on Toyota engine 4 cylinders in line
- Fully functional system
- Diagnosis through OBD 16 pole diagnostic socket
- Open contacts for measuring system components and circuits
- Fault code simulations

Order No.:MVMP12-Toyota-(engine)



**Educational petrol engine with direct injection system (GDI) EURO 3**

- Fully functional system
- Diagnosis through OBD 16 pole diagnostic socket
- Open contacts for measuring system components and circuits
- Fault code simulations

Order No.:MVGDI1



**Educational petrol engine with direct injection system (FSI) EURO 4**

- Fully functional system
- Diagnosis through OBD 16 pole diagnostic socket
- Open contacts for measuring system components and circuits
- Fault code simulations

Order No.:MVFSI1



**Educational petrol engine with direct injection system (TSI) EURO 5**

- Fully functional system
- 4 cylinders in line, 1.4 TSI
- Diagnosis through OBD 16 pole diagnostic socket
- Open contacts for measuring system components and circuits
- Fault code simulations

Order No.:MVTSI1



**Educational petrol engine with direct injection system (TSI) EURO 5**

- Fully functional system
- 4 cylinders in line, 1.2 TSI, 8 Valve, OHC
- Diagnosis through OBD 16 pole diagnostic socket
- Open contacts for measuring system components and circuits
- Fault code simulations

Order No.:MVTSI1



**Educational hybrid Engine model**

- Fully functional system
- Diagnosis through OBD 16 pole diagnostic socket
- Open contacts for measuring system components and circuits
- Fault code simulations

Order No.:MVHY1



**Educational petrol engine with LPG system (MPI+LPG) EURO 3**

- Fully functional system
- Diagnosis through OBD 16 pole diagnostic socket
- Open contacts for measuring system components and circuits
- Fault code simulations

Order No.:MVMP1-LPG1



**Educational petrol engine with LPG system (MPI+LPG) EURO 4**

- Fully functional system
- Diagnosis through OBD 16 pole diagnostic socket
- Open contacts for measuring system components and circuits
- Fault code simulations on engine management system

Order No.:MVMP1-LPG2



# Working engine models



**Educational diesel engine with VE pump (TDI) EURO 2**

- Fully functional system
- Diagnosis through OBD 16 pole diagnostic socket
- Open contacts for measuring system components and circuits
- Fault code simulations

Order No.:MVVE1



**Educational diesel engine with PD system EURO 3**

- Fully functional system
- Diagnosis through OBD 16 pole diagnostic socket
- Open contacts for measuring system components and circuits
- Fault code simulations

Order No.:MVDP1



**Educational Diesel engine with CR (Common Rail) system EURO 3**

- Fully functional system
- Diagnosis through OBD 16 pole diagnostic socket
- Open contacts for measuring system components and circuits
- Fault code simulations

Order No.:MVCR1



**Educational Diesel engine with CR (Common Rail) system EURO 4**

- Fully functional system
- Diagnosis through OBD 16 pole diagnostic socket
- Open contacts for measuring system components and circuits
- Fault code simulations

Order No.:MVCR2



**Educational Diesel engine with CR (Common Rail) system EURO 5**

- Fully functional system
- Diagnosis through OBD 16 pole diagnostic socket
- Open contacts for measuring system components and circuits
- Fault code simulations
- Hidden faults simulation for students examination

Order No.:MVCR3



**Eddy Current brake**

- Frame on 4 wheel, with the protection guards
- Assembly flange at flywheel of the engine
- Drive shaft with coupling
- PC based software compatible with Win 7, 8
- Eddy current brake controlling device with information screen
- Emergency stop button

! Should be ordered with the educational engine at once!

Order No.:Dyno400



**Eddy Current brake**

- Frame on 4 wheel, with the protection guards
- Assembly flange at flywheel of the engine
- Drive shaft with coupling
- PC based software compatible with Win 7, 8
- Eddy current brake controlling device with information screen
- Emergency stop button

! Should be ordered with the educational engine at once!

Order No.:Dyno-800



**Eddy Current brake**

- Frame on 4 wheel, with the protection guards
- Assembly flange at flywheel of the engine
- Drive shaft with coupling
- PC based software compatible with Win 7, 8
- Eddy current brake controlling device with information screen
- Emergency stop button

! Should be ordered with the educational engine at once!

Order No.:Dyno-1000



# Working engine models



## Educational petrol engine with Multipoint injection system + Dyno

- Fully functional system
- Diagnosis through OBD 16 pole diagnostic socket
- Open contacts for measuring system components and circuits
- Fault code simulations

Educational engine connected with the engine dynamometer complete with:

- Eddy current brake
- Frame on 4 wheel, with the protection guards
- Assembly flange at flywheel of the engine
- Drive shaft with coupling
- PC based software compatible with Win 7, 8
- Eddy current brake controlling device with information screen
- Emergency stop button

Order No.:MVMPI+Dyno



## Educational petrol engine with direct injection system (TSI) EURO 5 + Dyno

- Fully functional system
- Diagnosis through OBD 16 pole diagnostic socket
- Open contacts for measuring system components and circuits
- Fault code simulations

Educational engine connected with the engine dynamometer complete with:

- Eddy current brake
- Frame on 4 wheel, with the protection guards
- Assembly flange at flywheel of the engine
- Drive shaft with coupling
- PC based software compatible with Win 7, 8
- Eddy current brake controlling device with information screen
- Emergency stop button

Order No.:MVTSI+Dyno



## Hidden fault simulation for engine control system

- 12 fault simulation (hidden from students)
- Closed box

Should be ordered together with the stand!

Order No.:AE12F-ENG



## Vacuum measuring gauge

Should be ordered together with the stand!

Order No.:AEVAC-ENG



## Fuel pressure gauge

The pressure gauge in the low fuel supply line for petrol engine (systems with the fuel pump in tank only)

Should be ordered together with the stand!

Order No.:AEPRES-P-ENG



## Fuel pressure gauge

- 12 fault simulation (hidden from students)
- Closed box

Should be ordered together with the stand!

Order No.:AEPRES-D-ENG



# Working engine models



**Educational Truck Diesel engine with VR type pump**

- Fully functional system
- 4 cylinders in line
- Diagnosis through diagnostic socket
- Open contacts for measuring system components and circuits
- Fault code simulations

Order No.:MVSVR1



**Educational Truck Diesel engine with PLD system**

- Fully functional system
- 6 cylinders in line
- Diagnosis through pole diagnostic socket
- Open contacts for measuring system components and circuits
- Fault code simulations

Order No.:MVSPLD2



**Educational Truck Diesel engine with CR system (Common Rail)**

- Fully functional system
- 4 cylinders in line
- Diagnosis through OBD 16 pole diagnostic socket
- Open contacts for measuring system components and circuits
- Fault code simulations

Order No.:MVSCR1



**Educational Truck Diesel engine with CR system (Common Rail)**

- Fully functional system
- 6 cylinders in line
- Diagnosis through OBD 16 pole diagnostic socket
- Open contacts for measuring system components and circuits
- Fault code simulations

Order No.:MVSCR6



**Educational Truck Diesel Engine V8**

- Fully functional system
- Diagnosis through OBD 16 pole diagnostic socket
- Open contacts for measuring system components and circuits
- Fault code simulations

Order No.:MVSCR3

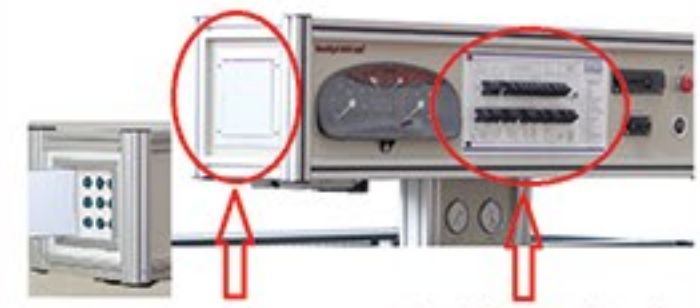

12 hidden faults simulation in closed box

Standard faults simulation by disconnecting jumpers

**Hidden fault simulation for Engine control system**

- 12 fault simulation (hidden from students)
- Closed box

Should be ordered together with the stand!

Order No.:AE12F-ENG

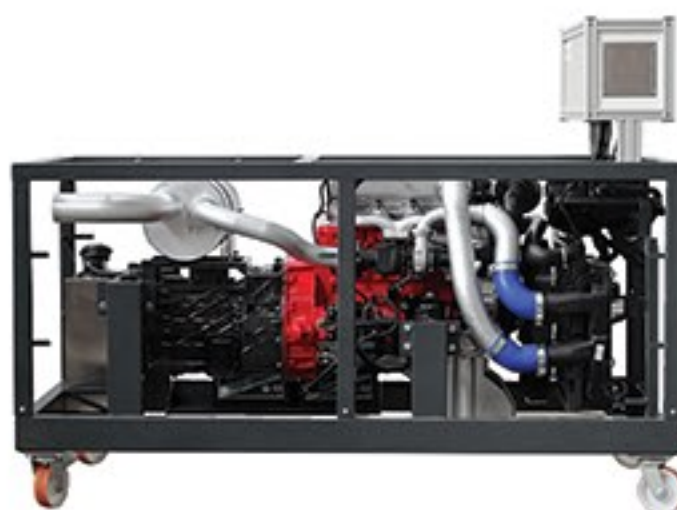

**Educational Truck Diesel engine With PLD system**

- Fully functional system
- 4 cylinders in line
- Diagnosis through diagnostic socket
- Open contacts for measuring system components and circuits
- Fault code simulations

Order No.:MVSPLD1



# Truck tachograph simulator, Brake rigs and Engine stand



**Truck digital educational tachograph simulator**

- Fully functional system
- Driving speed simulation
- Rest and driving time modes
- 3 cards included: Driver Card, Workshop Card, Company Card
- Print driving reports
- Multilanguage

Order No.:MSTACH02



**Truck analogue educational tachograph simulator**

- Fully functional system
- Driving speed simulation
- Print driving reports
- Multilanguage
- With analogue paper tachograph charts

Order No.:MSTACH03



**Brake rigs**

- Fully functional system with ABS
- Brake booster, front and rear discs with calipers, cross diagonal hydraulic circuit, hand brake
- Diagnosis through OBD 16 pole diagnostic socket
- Driving simulation
- 4 measuring gauges
- Mobile, with 4 casters

Order No.:MSSS01



**Automotive 12V Starter functional model**

- Starter model on the aluminum base
- Complete with the bendix drive, ignition switch, protection plexiglass, connection cables
- Real automotive components;
- Starter running without the load;

Order No.:AVS1



**Electromechanical parking brake EPB stand**

- Functional electromechanical parking brake complete with the brake disc, brake caliper, multi stage gear mechanism, electric motor
- Two electrical buttons for press and release brake pads
- The brake operates electrically at 12V/ 220 volts
- Cutaway of multi stage gear mechanism

Order No.:MSEPS1



**Electronic steering rig**

- Fully functional system
- Rack and pinion type
- Electro hydraulic power steering system
- Diagnosis through OBD 16 pole diagnostic socket
- Driving simulation
- Mobile, with 4 casters

Order No.:MSEVS1



**Hydraulic steering rig**

- Fully functional system
- Rack and pinion type
- Hydraulic power steering system
- Power supply 220 volts
- Mobile, with 4 casters

Order No.:MSMPI1



**Engine stand**

- Allows 360° rotation of engine or gearbox
- Reducer with worm gear for engine rotation
- Adjustable mounting brackets easily fit to engine block or gearbox
- 4 adjustable supports for braking and stability
- Mobile, with 4 casters
- Stainless steel drain pan

Order No.:VV1



# Engines and gearboxes for disassembling and assembling



## Engines for disassembling and assembling

- Passenger donor car diesel or petrol engines with different fuel supply systems (MPI, FSI, GDI, CR, VE and another on customer request)
- On manually 360° rotating stand with worm and wheel gearboxes
- Mobile, with 4 castors

Order No.:VIVV1



## Petrol MPI Turbo Engine for disassembling and assembling

- Passenger donor car petrol engines with MPI type fuel supply system and turbo
- Complete timing an auxiliary belt
- No wiring diagram or sensors
- On manually 360° rotating stand with worm and wheel gearboxes
- Mobile, with 4 castors

Order No.:VIVV1-ADRT



## Petrol MPI Engine for disassembling and assembling

- Passenger donor car petrol engines with MPI type fuel supply system
- Complete timing an auxiliary belt
- No wiring diagram or sensors
- On manually 360° rotating stand with worm and wheel gearboxes
- Mobile, with 4 castors

Order No.:VIVV1-ADR



## Engine with GDI direct petrol injection for disassembling and assembling

- Complete passenger donor car engine
- Complete timing an auxiliary belt
- No wiring or sensors
- On manually 360° rotating stand with worm and wheel gearboxes
- Mobile, with 4 castors

Order No.:VIVV1-GDI



## Diesel CR Turbo Engine for disassembling and assembling

- Passenger donor car Diesel engine with CR type fuel supply system and turbo
- Complete timing an auxiliary belt
- No wiring diagram or sensors
- On manually 360° rotating stand with worm and wheel gearboxes
- Mobile, with 4 castors

Order No.:VIVV1-RHX



## Turbo diesel engine with VE/ER pump for disassembling and assembling

- Passenger donor car Diesel engine with VE/VR type pump and turbo
- Complete timing an auxiliary belt
- No wiring or sensors
- On manually 360° rotating stand with worm and wheel gearboxes
- Mobile, with 4 castors

Order No.:VIVV1-VETDI



## Turbo Diesel DOHC engine in split version on rotating stand

- Passenger donor car diesel engine in split version
- 6 cylinders in line, DOHC with the chain
- Cutaway of 3 cylinders to show the working order
- Including the Common rail pump and injector
- On manually 360° rotating stand with worm and wheel gearboxes
- Mobile, with 4 castors

Order No.:IVD-Split



## Gearboxes for disassembling and assembling

- Passenger donor car, automatic CVT Multitronic gearbox
- On manually 360° rotating stand with worm and wheel gearboxes
- Mobile, with 4 castors

Order No.:GDVV1-MULTI



## Gearboxes for disassembling and assembling

- Passenger donor car manual or automatic gearboxes in different configuration ( 4, 5, 6 – speed , automatic , DSG, multitronic, variable and another on customer request)
- Mobile, with 4 castors on manually 360° rotating stand with worm and wheel gearboxes

Order No.:GDIVV1



# Vehicle Functional model



## Wheel alignment Training stand

- Suspension angles modification on front and rear axles
- Toe angle modification on front and rear axles
- Camber angle modification on front and rear axles
- Caster angle modification, Cradle adjustment
- Steering rack modification
- All suspension components are visible and easily adjustable

Order No.:MSVAZ1



## Toyota PRIUS II Hybrid 1/2

- Educational fully operational vehicle.
- Electrical system with the front end fully functional
- Alternative to complete vehicle - space saving version, complete front end with complete back electrical part, the bumper and tail light.
- Two front wheels and rear mounted rollers for movement
- Engine, ABS, AC, Air BAG's and etc. diagnostics

Order No.:PMTP-01



## Toyota PRIUS II Hybrid 1/2 (Cabrio version)

- Electrical system with the front end fully functional
- Alternative to complete vehicle - space saving version
- Two front wheels and rear mounted rollers for movement
- Engine, ABS, AC, Air BAG's and etc. diagnostics

Order No.:PMTPK-01



## Functional Vehicle

- Educational fully operational vehicle.
- Cutaway of different body and internal parts

Order No.:AE-FV



## Built in measuring box with open contacts and wiring diagram for engine control system

- Should be ordered together with the car
- Max 2 systems per car

Order No.:PMTP-ENG/Box

Fault simulation for engine control system (10 faults)

Order No.:PMTP-ENG/Faults



## Built in measuring box with open contacts and wiring diagram for climate control

- Should be ordered together with the car
- Max 2 systems per car

Order No.:PMTP-AC/Box

Fault simulation for climate control (6 faults)

Order No.:PMTP-AC/Faults



## Built in measuring box with open contacts and wiring diagram for SRS AIRBAG

- Should be ordered together with the car

Order No.:PMTP-SRS/Box

Fault simulation for SRS AIRBAG (6 faults)

Order No.:PMTP-SRS/Faults



## Timing belt and chain replacement trainers

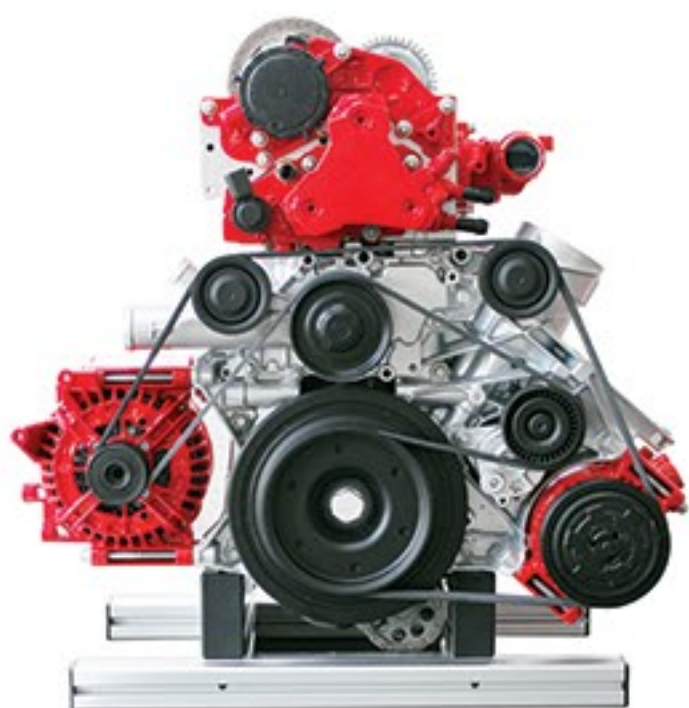

**Diesel DOHC Common Rail engine 1/2 cutaway model**

- For timing chain replacement training
- Auxiliary drive belt replacement training
- 4 valves per cylinder
- Water cooling
- 12V alternator

Order No.:IVDD-CR02



**Petrol DOHC engine 1/2 cutaway model**

- For timing belt replacement training
- Auxiliary drive belt replacement training
- DOHC twin overhead camshaft
- 4 valves per cylinder
- Water cooling
- 12V alternator
- Including the special tools for timing

Order No.:IVDB01



**Diesel OHC Common Rail Engine 1/2 cutaway model**

- For timing belt replacement training
- Auxiliary drive belt replacement training
- 2 valves per cylinder
- Water cooling
- 12V alternator
- Including the special tools for timing

Order No.:IVOD-CR01



**Petrol DOHC engine 1/2 Cutaway model**

- For timing chain replacement training
- Auxiliary drive belt replacement training
- DOHC twin overhead camshaft
- 4 valves per cylinder
- Water cooling
- 12V alternator

Order No.:IVDB02



# Cutaway and other educational models

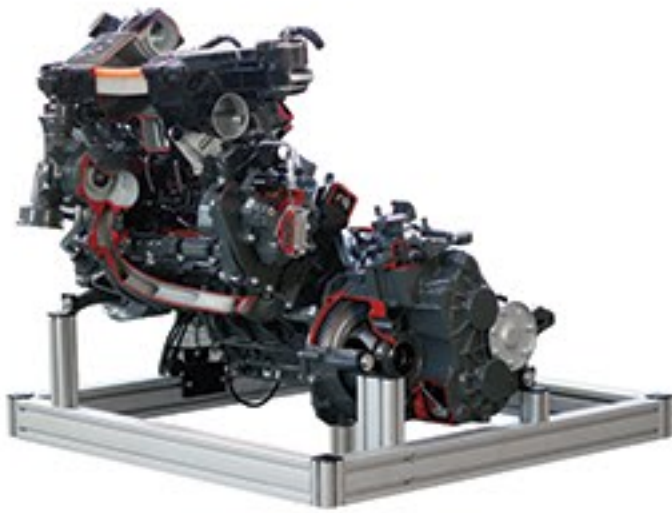

**Diesel Common rail  
INJECTION + GEARBOX cutaway model**

- 4 in-line cylinders
- Camshaft
- Gearbox 5 forward speeds + reverse
- The engine operates electrically at 220 volts and runs at a reduced speed.
- Operation of the various mechanical parts
- The cutaway engine model on aluminium stand with the wheels

Order No.:AEMBA170



**Direct shift gearbox  
Cutaway model**

- The DSG gearbox model is mounted on the stand
- Manual rotation
- The cutaway gearbox model on aluminium base;

Order No.:AE1064



**Petrol DOHC  
Engine 1/4 cutaway model**

- DOHC twin overhead camshaft
- 4 valves per cylinder
- Piston with the rings
- 1 cylinder
- The cutaway model on aluminium base

Order No.:IVDB1/4



**Diesel engine 1/4  
Cutaway model**

- 2 valves per cylinder
- Piston with the rings
- 1 cylinder
- The cutaway model on aluminium base

Order No.:IVOD1/4



**Membrane spring clutch  
Cutaway functional model**

- On the base
- Complete with the flywheel, clutch disc, pressure plate, throw out bearing and release fork and pressing handle
- Rotation of the clutch disk by hand
- The cutaway clutch model on aluminium base

Order No.:IDSS



**Dual mass flywheel with the  
Clutch cutaway model**

- On the base

Order No.:AE-DMF



**Truck Turbo charger  
Cutaway model**

- On the base

Order No.:AETTC



**Ignition &  
Charging System**

- A plastic-plated wooden base is the support of the main components of the coil ignition of a 4-stroke engine: battery, spark coil, coil, spark plugs.
- Rotating the flywheel, it shows the operation of the whole unit (the action of the platinum points and of the distributor can be observed through the section) and the spark flashing in the respective spark plugs is shown as well.

Order No.:AE410000E



**12 Volt Battery cutaway model**

- Battery type lead / acid

Order No.:AE410040S



# Cutaway and other educational models



**12 Volt AGM  
Battery cutaway**

- Battery type Absorbed Glass Matte
- Mostly used for Start/Stop systems

Order No.:AE410041



**Starter motor for cars  
Cutaway model**

- Passenger cars
- On the base

Order No.:AE410070M



**Starter motor with reduction gears  
Cutaway model**

- Passenger cars
- On the base

Order No.:AE410071M

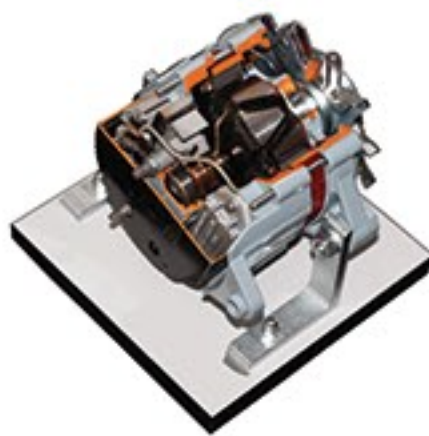

**Alternator single-flow cooling  
Cutaway model**

- On the base

Order No.:AE410080M



**Alternator double-flow cooling  
Cutaway model**

- On the base

Order No.:AE410081M

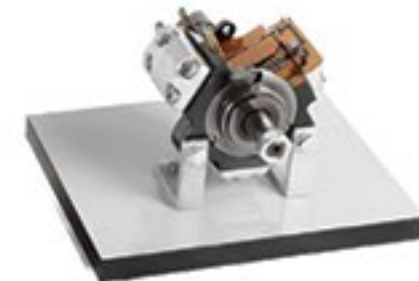

**CP1 bosch high pressure pump  
Cutaway model**

- Radial-piston pump for common rail engines
- Pressure up to 1350 bar
- Fuel lubricated
- Three plungers
- Cutaway model on the base

Order No.:AE410104M



**CP3 bosch high pressure pump  
Cutaway model**

- Radial-piston pump for common rail engine
- Pressure up to 1600 bar
- Fuel lubricated
- Three plungers
- Cutaway model on the base

Order No.:AE410106M



**CP4 bosch high pressure pump  
Cutaway model**

- Radial-piston pump for common rail engine,
- Pressure up to 2000 bar
- Fuel lubricated
- Two plungers
- Cutaway model on the base

Order No.:AE410108M

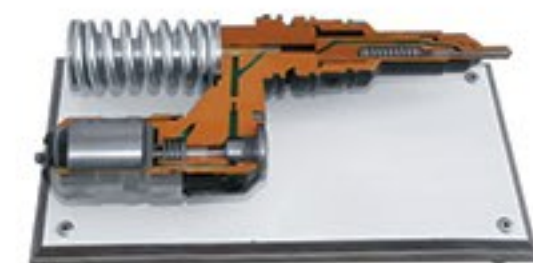

**Injector pump  
Cutaway model**

Accurate section of a unit injector system for commercial vehicle, where it is possible to observe:

- Electromagnetic valve HD
- Pumping element
- Duster, etc.
- Cutaway model on the base

Order No.:AE410110S



# Cutaway and other educational models



**Common rail piezo injector  
Cutaway model**

- On the base

Order No.:AE410112S



**Diesel injection pump with 6 IN-LINE cylinders and centrifugal governor cutaway model (on base)**

- Small piston
- Cylinder
- Sector gear
- Rock
- Camshaft
- Check valve
- Centrifugal governor
- Manual operation

Order No.:AE410180M



**Diesel injection pump with 4 IN-LINE cylinders and centrifugal governor cutaway model (on base)**

- Small piston
- Cylinder
- Sector gear
- Rock
- Camshaft
- Check valve
- Centrifugal governor
- Manual operation

Order No.:AE410181M



**INJECTION PUMP WITH 6 IN-LINE CYLINDERS cutaway model**

- Small piston, Cylinder, Sector gear, Rock, Camshaft, Check valve, Centrifugal governor, 2 injectors of different type, Fuel filter, Fuel pump, Operated manually through a crank handle.
- Cutaway model on the base

Order No.:AE410200M



**Bosch injection pump with 4 in-line cylinders + pneumatic speed governor cutaway model**

- Accurate section of a pump suitable for medium displacement engine (FIAT, Mercedes) with pneumatic speed governor (rock rod or acceleration rod controlled by a diaphragm connected to the suction collector). It is provided with a feeding pump.
- Cutaway model on the base

Order No.:AE410220M



**Single cylinder injection pump  
Cutaway model**

- On the base

Order No.:AE410230M



**BOSCH VE rotary injection pump  
Cutaway**

- Distributor plunger
- Injection phase
- Supplied complete with an indirect injector
- Manual operation
- Cutaway model on the base

Order No.:AE410240M



**CAV DPA-DPS Rotary injection pump  
Cutaway model**

- Careful section of a CAV rotary pump for training purposes, showing all its operating parts. The transfer pump, the speed governor, the automatic advance regulator, the hydraulic sensor device, the fuel circuit and the pumping small piston are clearly shown. It is supplied complete with an indirect injector.
- Manual operation
  - Cutaway model on the base

Order No.:AE410250M



**CAV DPC injection pump  
Cutaway model**

- Cross sectioned according to the criteria to show its main parts. It is provided with an indirect injector.
- Manual operation
  - Cutaway model on the base

Order No.:AE410260M



# Cutaway and other educational models



**Diesel injection VP 44  
Bosch pump cutaway**

- Distributor plunger
- Injection phase
- Electronic control unit, etc.
- Manual operation
- Cutaway model on the base

Order No.:AE410270M



**Diesel injector  
Cutaway model**

- Careful section of two different injectors (direct and indirect injection type) showing their internal parts and relevant operation
- Cutaway model on the base

Order No.:AE410280S

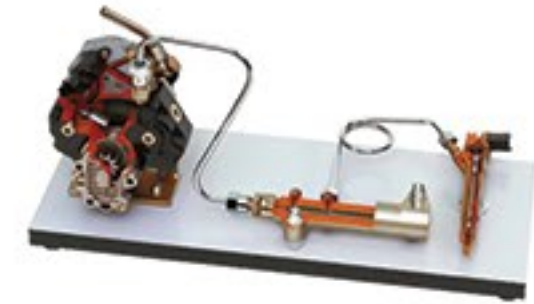

**DIESEL COMMON-RAIL  
(on base) – manual**

- Accurate cross-section of the high pressure (1600 bar) fuel system known as Common-rail. This circuit consists of a radial piston pressure pump, one delivery manifold and an electro-injector, all connected via high pressure hoses.
- Cutaway model on the base

Order No.:AE410300M



**Diesel Common Rail injector with  
solenoid valve cutaway model**

- Section of electro injector for modern diesel engines. The main interesting components from the educational point of view are displayed.

Order No.:AE410305S



**Electrical fuel pump  
(on base) - static**

- On the base

Order No.:AE410380S



**Turbocharger with waste-gate valve  
(on base)**

- On the base

Order No.:AE410430M



**LPG FUEL CIRCUIT  
(on base) – static**

- Layout of a car LPG fuel system with single-body type carburettor for educational purposes included: Filler Plug, LPG tank, Level gauge, LPG solenoid valve, Petrol solenoid valve, Vaporizer reduction gear, Carburettor.

- Cutaway model on the base

Order No.:AE410520S



**LPG TIMED SEQUENTIAL INJECTION FOR  
ELECTRONIC INJECTION ENGINES (wall-mounted)  
– cutaway training model**

- LPG timed sequential injection for petrol engine with multi-point electronic injection, complete with the following components: ECU, Injection rail, L.P.G. solenoid valve, Reducer – vaporizer, Pressure sensor, Pressure stabilizer, Switch commutator, Nozzles for manifold, Water temperature sensor, Gas temperature sensor, Refuelling valve, Level indicator

Order No.:AE410525S



**Hydraulic shock absorber  
Cutaway model**

- McPherson type
- Complete with the damper spring
- On the base

Order No.:AE410636



# Cutaway and other educational models



**Gas shock absorber  
Cutaway model**

- On the base

Order No.:AE410638

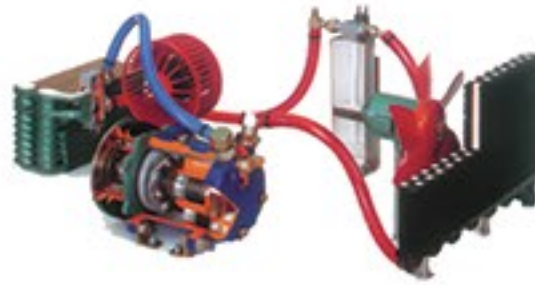

**Air conditioning system  
(on base) – manual**

Radial piston compressor, Condenser, Filter, Expansion valve, Evaporator, Electric fans, High and low pressure connecting hose

Order No.:AE410650M



**Rack and pinion, steering box  
Cutaway model**

- On the base

Order No.:AE410730M



**Rack power steering  
Training model**

- Rack type steering box
- Hydraulic pump
- Oil tank with relevant filter
- Connecting pipes
- For cars
- On base

Order No.:AE410760M



**Electrical rack and pinion steering  
Cutaway model**

- Manual operation
- Cutaway model on the base

Order No.:AE410782M



**Gearbox  
Cutaway model**

- 5 speed forward and one reverse
- With possibility of selecting any speed
- Operated manually through a hand wheel
- Gearbox cutaway model on stand with wheels

Order No.:AE410990M



**Gearbox  
Cutaway model**

- 5 speed forward and one reverse
- With the differential
- With possibility of selecting any speed
- Operated manually through a hand wheel
- Gearbox cutaway model on stand with wheels

Order No.:AE411005M



**Gearbox front wheels drive  
Cutaway model**

- 6 speed forward and one reverse
- With the differential
- With possibility of selecting any speed
- Operated manually through a hand wheel
- On stand with wheels

Order No.:AE411006



**GEARBOX WITH CLUTCH 5 FORWARD SPEEDS +  
REVERSE cutaway model**

This cutaway model is carefully sectioned for training purposes, professionally painted with different colors to better differentiate the various parts and cross-sections. Many parts have been chromium-plated and galvanized for a longer life.

Main Technical Specifications:

- Dry single-plate clutch with spring and diaphragm. The clutch is operated mechanically by means of a foot pedal for training purposes.
- Operated manually through a hand wheel
- Gearbox cutaway model on stand with wheels

Order No.:AE411030



# Cutaway and other educational models



**Automatic transmission  
Cutaway model**

- Operated manually through a hand wheel
- Gearbox cutaway model on stand with wheels

Order No.:AE411040M



**Automatic  
Transmission**

- Rear drive 4 Forward + reverse
- Rotation manually, by handle
- Casing, Torque converter
- Oil pump, Stationary plate clutch
- Rotary plate clutch, Planetary gear train
- Hydraulic circuit valve, Centrifugal regulator
- The gearbox cutaway model is mounted on the stand with the wheels

Order No.:AE411060M



**CONTINUOUSLY VARIABLE TRANSMISSION  
(CVT) Cutaway model**

- Special gearbox that can change continuously through an infinite number of effective gear ratios between maximum and minimum values. There are two V-belt pulleys that are split perpendicular to their axes of rotation, with a V-belt running between them.
- Operated manually through a hand wheel
  - Gearbox cutaway model on stand with wheels

Order No.:AE411068M



**ZF 16S ECOSPLIT GEARBOX FOR HEAVY TRUCKS  
16F + 2R cutaway model**

- The gearbox is composed of a central box containing 4 forward speeds gearings and 2 reverse speeds gearings, epicyclic unit for selecting the speed-gears mounted on the base and over-gear on top. The over-gear allows to divide each gear into slow or fast obtaining 16 forward gears which can be inserted and geared down in sequence.
- Heavy vehicles gearbox, With possibility of selecting any speed
  - Operated manually through a hand wheel; Gearbox cutaway model on stand with wheels; Weight approx. – 400 kg

Order No.:AE411069M



**FULLER 13 SPEED GEARBOX cutaway model**

- Quick change gear box used in 300/400HP heavyweight vehicles with mechanical and pneumatic control. It is a non-synchronized gearbox, the box is divided in 2 parts:
- On the engine side there are 1st 2nd 3rd and 4th speed gears, reverse speed gears and extra low ratio pick-up speed gears. All these gears are mechanically controlled by the change gear lever. In the other part of the gearbox (on the output shaft side), there are the standard, low ratio and semi low ratio speed gears, pneumatically controlled by the pre-selectors provided on the gear lever. This gearbox is made very sturdy by the presence of 2 auxiliary shafts sharing stress to an equal degree.

Order No.:AE411070M



**Heavy truck gearbox zf 5hp  
Cutaway model**

- Sectioned heavy truck gearbox. Composed by:
- Torque converter with lock-up clutch
- Hydrodynamic retarder, Rotating multi-disc clutches
- Fixed-position multi-disc brakes, Oil cooler with oil-water exchanger, Electro- valves
- Operated manually through a hand wheel
- Gearbox cutaway model on stand with wheels
- Weight approx. – 350 k

Order No.:AE411071M



**Gearbox with triple reduction gear  
Cutaway model**

- Heavy vehicles gearbox
- With possibility of selecting any speed
- Operated manually through a hand wheel
- Gearbox cutaway model on stand with wheels
- Weight approx. – 200 kg

Order No.:AE411080M



**Hybrid transmission mg (motor/generator)  
Toyota Prius**

- The Motor Generator 1 (MG1) operates as the control element for the power splitting planetary gear set. It recharges the HV battery and also supplies electrical power to drive Motor Generator 2 (MG2). MG1 effectively controls the continuously variable transmission function of the transaxle and operates as the engine starter.
- Operated manually through a hand wheel;
  - Gearbox cutaway model on stand with wheels

Order No.:AE411082M



**Single disc clutch  
Coil spring model**

- Clutch disc, pressure plate, throw out bearing and release fork and pressing handle
- Rotation of the clutch disk by hand
- Clutch cutaway model on the base

Order No.:AE41110M



# Cutaway and other educational models



**Centrifugal clutch  
Cutaway model**

- On the base

Order No.:AE411141M



**Rear axle heavy truck with locking  
differential cutaway model**

- Rear axle for heavy truck with locking differential. • Complete section of the rear axle. The main components are: • Bevel gear (pinion – crown) • Differential (satellite and planetary) with locking differential • Axle shafts • Reducer and planetary on the hub • Brakes with jaws/drum • Double air brake element • Operated manually • Truck axle cutaway model on stand with wheels

Order No.:AE411198M



**Rear axle heavy truck without locking  
Differential cutaway model**

- Rear axle for heavy truck with locking differential. • Complete section of the rear axle. The main components are: • Bevel gear (pinion – crown) • Differential (satellite and planetary) with locking differential • Axle shafts • Reducer and planetary on the hub • Brakes with jaws/drum • Double air brake element • Operated manually • Truck axle cutaway model on stand with wheels

Order No.:AE411199M



**Rear suspension  
Model**

- Rear suspension with the sectioned shock absorbers, springs and brake drums
- Suspension model mounted on stand with wheels

Order No.:AE411204M



**Sectioned front  
Suspension unit**

- McPherson Strut Type Suspension
- Shock absorber, spring
- Rack and pinion steering box
- Disc brake
- Steering wheel
- Sectioned suspension mounted on the stand with wheels

Order No.:AE411210M



**Hydraulic brake  
chassis trainer**

- McPherson suspension • Shock absorber • Spring • Rack and pinion steering box • Disc brake • Drum brake • Hydraulic pump • Brake lever • Steering wheel • Sectioned chassis mounted on the stand with wheels

Order No.:AE411220M



**Viscous coupling differential  
Cutaway model**

- Accurate section of an assembly including a Ferguson type viscous coupling differential for four-wheel drive (4x4) motorcars.
- Original vehicles components.
  - Manual operation
  - Cutaway model on the base

Order No.:AE311250



**Self-locking hypoid differential  
Cutaway model**

- Accurate section of an assembly including hypoid bevel gear pair with self-locking differential
- Original vehicles components.
  - Manual operation
  - Cutaway model on the base

Order No.:AE311260



**Hypoid differential  
Cutaway model**

- On stand

Order No.:AE411280M



# Cutaway and other educational models



**4x4 vehicle transmission assembly with 5 speed mechanical**

- Gearbox: 5 forward speeds+ reverse • 2-Speeds reduction gear • Movement restorer with front wheel drive manual control • Drive shafts with universal joints • Self-locking hypoid differentials • Manual operation • Sectioned transmission assembly mounted on the stand with wheels

Order No.:AE411300M



**Drum brake Cutaway model**

- Section of a drum brake
- The cylinder and shoes are clearly shown.
- Brake cutaway model on the base

Order No.:AE412010M



**Disc and drum brake Cutaway model**

- A cutaway model of a hydraulic brakes. Composed of brake master cylinder, brake tank and brake lever. Caliper with the brake disc with the drum brake inside
- Sectioned brake model mounted on the base;

Order No.:AE412030M



**Hydraulic dual circuit brake with servo Brake training unit**

- Cut-away model used for training on servo double circuit mechanism hydraulic circle. Real parts of a car installed on a panel. When we press on brake pedal, hydraulic system start and turn on brake light and able to see the mechanism of brake. It shows brake pressure at the same time.
- Wall mounted training unit

Order No.:AE412050M

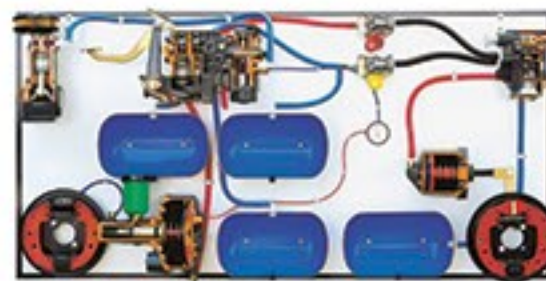

**Pneumatic air brake trainer**

- Wall panel showing the hydro-pneumatic braking elements of a truck (tractor-trailer) complete with: air compressor, triplex distributor with adjusting and control unit, pressure brake booster, tractor-trailer coupling joint, hydraulic control braking element, mechanical and air control braking element for parking braking, servo-distributor valve for the trailer, no. 4 air reservoirs (3 for the tractor). All elements are connected with rubber pipes of different colours to distinguish the various circuits.
- Wall mounted training unit

Order No.:AE412065S



**Angle reducer Cutaway model**

- On stand

Order No.:AE413092M



**Worm gear reducer Cutaway model**

- On stand

Order No.:AE413094M



**Single-stage reducer Cutaway model**

- On stand

Order No.:AE413096M



**Bevel helical reducer (On base) – manual**

- On stand

Order No.:AE413110M



# Cutaway and other educational models



**Hybrid system petrol/electric system  
Cutaway model**

- 4 in-line cylinders, 1500 cm<sup>3</sup> • Toyota hybrid system ( THS ) • VVT-I system ( Variable Valve Timing ) • Multi point injection • Engine + Electrical motors • Transmission with the differential group • The engine and the generator could be rotated manually • The Engine and the generator can operate together or separately. • The cutaway hybrid engine model mounted on the stand with the wheels.

Order No.:AE34500M



**Hybrid system petrol/electric system  
Cutaway model**

- 4 in-line cylinders, 1500 cm<sup>3</sup> • Toyota hybrid system ( THS ) • VVT-I system ( Variable Valve Timing ) • Multi point injection • Engine + Electrical motors • Transmission with the differential group • The engine and the generator operates electrically at 220 volts and runs at a reduced speeds. • The Engine and the generator can operate together or separately. • The cutaway hybrid engine model mounted on the stand with the wheels

Order No.:AE34501



**16 valve 4 cylinders fiat engine with  
multi-point Electronic injection cutaway model**

- 4 in-line cylinders, DOHC twin overhead camshaft
- Displacement: 2000 cu. Cm
- Multipoint electronic injection with ignition- integrated control unit
- Vibration-damping balancing shafts
- Manual operation
- The cutaway engine model mounted on the stand with the wheels.

Order No.:AE34800E



**16 valve 4 cylinders fiat engine with  
multi-point electronic injection + gearbox 5  
forward speeds + reverse cutaway model**

- 4 in-line cylinders, 2000 cm<sup>3</sup>, DOHC twin overhead camshaft • Multipoint electronic injection • Vibration-damping balancing shafts • Gearbox 5 forward speeds + reverse • The engine operates electrically at 220 volts and runs at a reduced speed to let the student easily understand and observe the operation of the various mechanical parts. • The engine and the gearbox cutaway model is mounted on the stand with the wheels.

Order No.:AE34805E



**6v cylinders petrol engine with multi-point  
electronic injection cutaway model**

- 6 V cylinders
- Displacement: 2000-3000 cc
- DOHC
- Multi-point electronic injection
- Centrifugal water pump
- 12V alternator
- Manual operation
- The cutaway engine mounted on the stand with the wheels.

Order No.:AE35205



**Fiat petrol engine with carburettor + gearbox  
Cutaway model**

- 4 in-line cylinders
- Displacement: 1000/1300 cm<sup>3</sup>
- Camshaft in head, Carburettor, Electronic ignition, Timing belt distribution
- Gearbox: 5 forward speeds + reverse with differential
- The engine operates electrically at 220 volts and run at a reduced speed to let the student easily understand and observe the operation of the various mechanical parts
- The cutaway engine mounted on the stand with the wheels.

Order No.:AE35220-CE



**Fiat petrol engine with electronic injection -  
monojetronic + gearbox cutaway model**

- 4 in-line cylinders,
- Displacement: 1000/1300 cm<sup>3</sup>
- Camshaft in head, injection system, electronic ignition, Timing belt distribution
- Gearbox: 5 forward speeds + reverse with differential
- The engine operates electrically at 220 volts and run at a reduced speed to let the student easily understand and observe the operation of the various mechanical parts
- The cutaway engine mounted on the stand with the wheels.

Order No.:AE35220-IEM



**Fiat petrol engine with multi-point electronic  
injection + gearbox cutaway model**

- 4 in-line cylinders,
- Displacement: 1000/1300 cm<sup>3</sup>
- Camshaft in head, electronic injection, Electronic ignition, Timing belt distribution
- Gearbox: 5 forward speeds + reverse with differential
- The engine operates electrically at 220 volts and run at a reduced speed to let the student easily understand and observe the operation of the various mechanical parts
- The cutaway engine mounted on the stand with the wheels.

Order No.:AE35222-IEE



**2 cylinders petrol engine  
Cutaway model**

- Air cooling
- Displacement: 500 cu. Cm
- Camshaft in the crankcase
- Single body carburettor
- Overhead valves
- Manual operation
- The cutaway engine mounted on the base

Order No.:AE35230



# Cutaway and other educational models



## Single-cylinder 4 stroke petrol engine air Cooled cutaway model

- Displacement 160cc , power 6 hp
- camshaft in the crankcase
- overhead valves, RPM regulator
- oil pump, carburettor
- air filter, silencer, tank
- Manual operation
- The cutaway engine mounted on the base

Order No.:AE35245M



## Petrol multi-point engine chassis with ABS - chassis trainer

- Fiat chassis with front drive • Hydraulic power steering • With working light system • 4 cylinders, 1200 cm<sup>3</sup>, petrol • Electronic injection MPI (Multipoint) • Gearbox: 5 forward speeds + reverse+ differential • Hydraulic power steering with double-jointed steering column • Brake system with 4 sensors ABS • This cutaway model is carefully sectioned for training purposes, professionally painted with different colours to better differentiate the various parts, cross-sections, Lubricating circuits, fuel system, cooling system etc. • Many parts have been chromium, plated and galvanized for a longer life. • The engine operates electrically at 220 volts and run at a reduced speed to let the student easily understand and observe the operation of the various mechanical parts • The chassis trainer and the cutaway components is mounted on the stand with the wheels

Order No.:AE35272E



## Standard petrol multi-point engine chassis with working light system chassis trainer

- Fiat chassis with front drive 4 cylinders, 1200 cm<sup>3</sup>, petrol, electronic injection MPI (Multi-point) • Gearbox: 5 forward speeds + reverse+ differential • Double circuit brake system with servo brake • Front-disc brake, Rear-drum brake, Working front and rear light system controlled by a dashboard • This cutaway model is carefully sectioned for training purposes, professionally painted with different colours to better differentiate the various parts, cross-sections, Lubricating circuits, fuel system, cooling system etc. • Many parts have been chromium, plated and galvanized for a longer life. • The engine operates electrically at 220 volts and run at a reduced speed to let the student easily understand and observe the operation of the various mechanical parts • The chassis trainer and the cutaway components is mounted on the stand with the wheels

Order No.:AE35274E



## Fiat double shaft (DOHC) engine with multi-point electronic injection with light system chassis trainer

- 4-stroke petrol engine 4-cylinders
- Displacement 2000 cu Cm
- Gearbox: 5 speeds + reverse
- Differential with hypoid crown wheel and pinion
- Twin overhead camshaft driven by a toothed belt
- Electronic ignition
- Dual braking circuit
- McPherson front suspension
- Rack steering box
- Rear leaf spring suspension
- This cutaway model is carefully sectioned for training purposes, professionally painted with different colours to better differentiate the various parts, cross-sections, Lubricating circuits, fuel system, cooling system etc.
- Many parts have been chromium, plated and galvanized for a longer life.
- The engine operates electrically at 220 volts and run at a reduced speed to let the student easily understand and observe the operation of the various mechanical parts
- The chassis trainer and the cutaway components is mounted on the stand with the wheels.

Order No.:AE35340E

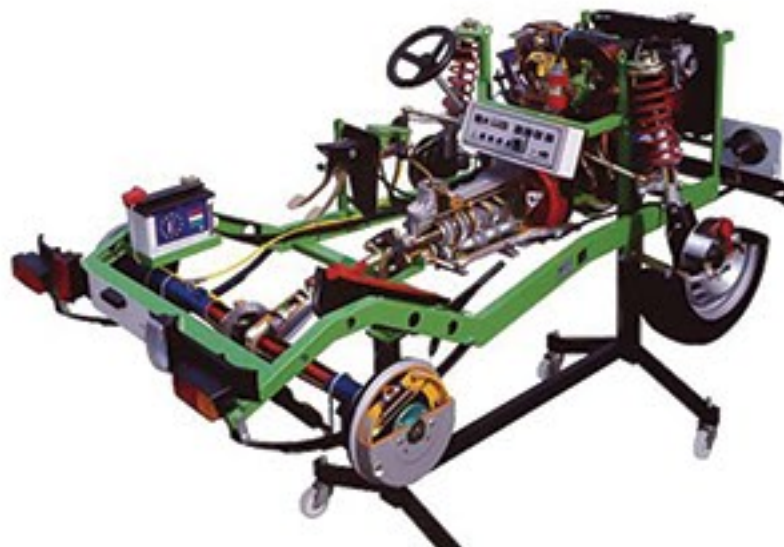

## Standard petrol multi-point engine chassis with working light system chassis trainer

- Fiat chassis with front drive 4 cylinders • 1200 cm<sup>3</sup>, petrol, electronic injection MPI (Multi-point) • Gearbox: 5 forward speeds + reverse+ differential • Double circuit brake system with servo brake • Front-disc brake • Rear-drum brake • Working front and rear light system controlled by a dashboard • This cutaway model is carefully sectioned for training purposes, professionally painted with different colours to better differentiate the various parts, cross-sections, Lubricating circuits, fuel system, cooling system etc. • Many parts have been chromium, plated and galvanized for a longer life. • The engine operates electrically at 220 volts and run at a reduced speed to let the student easily understand and observe the operation of the various mechanical parts • The chassis trainer and the cutaway components is mounted on the stand with the wheels.

Order No.:AE35350E



## Cutaway and other educational models



**Petrol multi-point engine chassis with ABS - chassis trainer**

- 4 stroke engine; 4 in-line cylinders, 4 valves per cylinder • Displacement: 2500/2800 cu. Cm • Power: 150-170 hp At 4000 RPM • Twin overhead camshaft (DOHC) with timing belt • Vibration-damping balancing shafts • Common rail-type direct injection with electro-injectors • Turbo-supercharger with air-air intercooler • Alternator-oil filter-oil pump • The engine operates electrically at 220 volts and run at a reduced speed to let the student easily understand and observe the operation of the various mechanical parts • The cutaway engine model components is mounted on the stand with the wheels

Order No.:AE36010M



**Fiat/alfa romeo 8 valve engine with turbo Diesel common-rail cutaway model**

- 4 stroke engine; 4 in-line cylinders; 2 valves per cylinder
- Turbo-supercharger
- Alternator-oil filter-oil pump
- The engine operates electrically at 220 volts and run at a reduced speed to let the student easily understand and observe the operation of the various mechanical parts

Order No.:AE36015E



**Sectioned engine mercedes atego, PLD system (injection pump) complete with all parts**

- 4 in-line cylinders • Camshaft • Operation of the various mechanical parts • On stand with wheels • This cutaway model is carefully sectioned for training purposes, professionally painted with different colours to better differentiate the various parts, cross-sections, Lubricating circuits, fuel system, cooling system etc. • The engine operates electrically at 220 volts and run at a reduced speed to let the student easily understand and observe the operation of the various mechanical parts • The truck cutaway engine is mounted on the stand with the wheels.

Order No.:AE36081



**6 cylinders diesel engine truck "Iveco" cursor with electronically controlled pump injectors cutaway model**

- Displacement: 7790/10380 cu Cm. according to what is available
- 4 stroke; 6 in-line cylinders
- 4 valves per cylinders
- maximum power 310/450hp according to what is available
- water cooling
- turbo-compressor
- pump injectors electronically controlled
- pre-heating device
- Operation of the various mechanical parts
- This cutaway model is carefully sectioned for training purposes, professionally painted with different colours to better differentiate the various parts, cross-sections, Lubricating circuits, fuel system, cooling system etc.
- The engine operates electrically at 220 volts and run at a reduced speed to let the student easily understand and observe the operation of the various mechanical parts
- The truck cutaway engine is mounted on the stand with the wheels.

Order No.:AE36083E



**Sectioned engine iveco, common rail system (CR) complete with all parts**

- 4 – 6 in-line cylinders • Camshaft • Operation of the various mechanical parts • This cutaway model is carefully sectioned for training purposes, professionally painted with different colours to better differentiate the various parts, cross-sections, Lubricating circuits, fuel system, cooling system etc. • The engine operates electrically at 220 volts and run at a reduced speed to let the student easily understand and observe the operation of the various mechanical parts • The truck cutaway engine is mounted on the stand with the wheels.

Order No.:AE36082



# Cutaway and other educational models

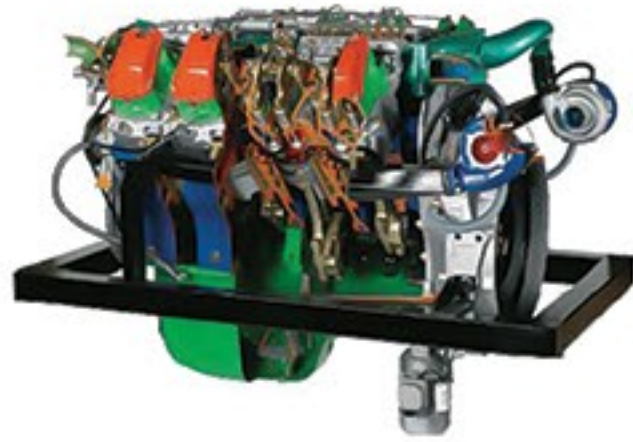

## Petrol multi-point engine chassis with abs - chassis trainer

- 4 stroke, 8 cylinders • Displacement: 17.200 cu.cm • Power: 380 hp • Direct injection • Bosch type in-line injection pump with mechanical governor • Intercooler water-oil • 4 valves per cylinder • Camshaft in the crankcase • 2 turbo-superchargers • Geared distribution • This cutaway model is carefully sectioned for training purposes, professionally painted with different colours to better differentiate the various parts, cross-sections, Lubricating circuits, fuel system, cooling system etc. • The engine operates electrically at 220 volts and run at a reduced speed to let the student easily understand and observe the operation of the various mechanical parts • The truck cutaway engine is mounted on the stand with the wheels.

Order No.:AE36084E



## Direct injection 2 stroke diesel engine Cutaway model

The most rational training model of a 4-stroke diesel engine sectioned for training purposes. Indirect injection, complete with injection pump, injector, pre-chamber, preheating glow plug, cooling system, distribution circuit, etc. Operated manually through a crank handle. In order to simulate the active stage of the cycle a small bulb lights up during the expansion phase.

- The cutaway engine model is mounted on the base;

Order No.:AE37100M



## 2 stroke petrol engine Cutaway model

- Piston displacement 46 cu. Cm
- Air cooling system
- Electronic ignition
- Box carburettor
- The cutaway engine model is mounted on the base;

Order No.:AE37450M



## Wankel Engine model

Rotating engine model, true to the original and complete with cutaway carburettor. The rotor (triangular piston), operated by the driving shaft, rotates inside the stator thus clearly showing the different phases. During the compression phase a small bulb lights up to simulate the petrol ignition. Light metal construction.

Order No.:AE37500M

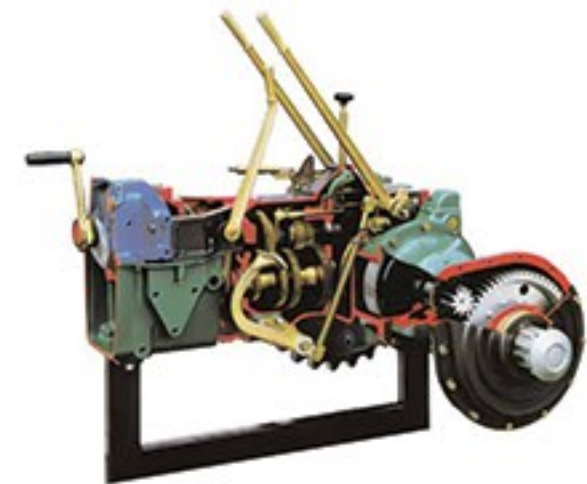

## Tracked tractor Transmission

- Clutch unit, Gearbox
- Pinion gear – ring gear
- Steering clutch, Final reducer
- The transmission is operated manually through a crank handle.
- The tractor transmission cutaway model is mounted on the stand with the wheels.

Order No.:AE38360M

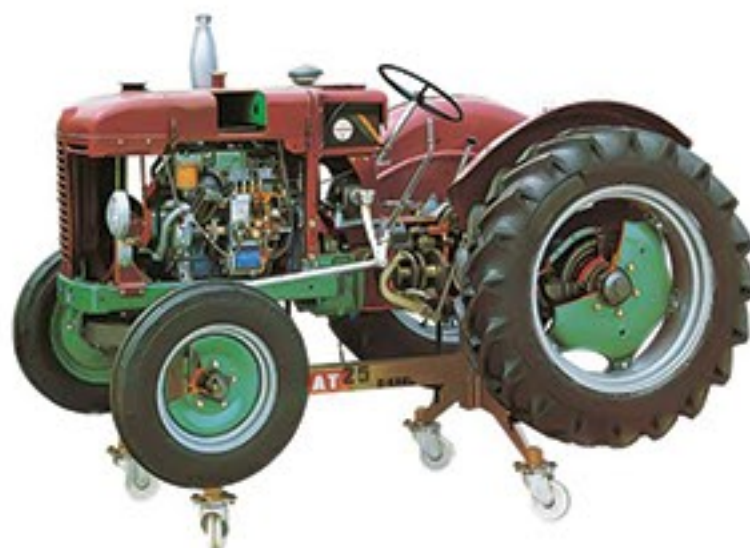

## Tyre-wheeled farm tractor with diesel engine - fiat 25r Cutaway model tractor engine

- 4-stroke – 4 cylinders engine • Displacement: 2000 cu.cm • Indirect injection • Water cooling system • Overhead valves • In-line injection pump • Globe-shaped steering box • Gearbox: 4 forward speeds + reverse • This cutaway model is carefully sectioned for training purposes, professionally painted with different colours to better differentiate the various parts, cross-sections, Lubricating circuits, fuel system, cooling system etc. • The engine operates electrically at 220 volts and run at a reduced speed to let the student easily understand and observe the operation of the various mechanical parts • The farm tractor cutaway is mounted on the stand with the wheels.

Order No.:AE38200E



## Opposed-piston Engine

- Air cooling system
- Gear distribution with camshaft in the crankcase
- Ignition with magneto
- Single-body carburettor
- The opposed pistons cutaway engine model is mounted on the stand with the wheels

Order No.:AE39260E





## Two post lift

- Lifting capacity 4000 kg
- Lifting height 1825 mm
- Electric motor power 2,2kW, 400V
- Mechanical locking of security fasteners
- Width between the columns 2806 mm

AEQ-240M



## Two post lift

- Lifting capacity 4000 kg
- Lifting height 1825 mm
- Electric motor power 2,2kW, 400V
- Electromagnetic locking of security fasteners
- Width between the columns 2806 mm

AEQ-240E



## Scissor lift, raises to a height of 1m

- Lifting capacity 3000 kg
  - Lifting height 1000 mm
  - Electric motor power 2,2kW, 400V
  - Adjustable platform length 1410 – 1958 mm
  - The lift is mobile, easy to transport.
  - Constructed on the floor.
- No extra base preparation required.

AEQ-S30-10



## In ground scissor lift

- Lifting capacity 3500 kg
- Lifting height 1800 mm
- Electric motor power 2,2kW, 400V
- Mounted into prepared pits
- Adjustable platform length 1550 – 1750mm

AEQ-S35-18IN



## Low profile scissor lift

- Lifting capacity 3200 kg
  - Lifting height 1830 mm
  - Electric motor power 2,2kW, 400V
  - Adjustable platform length 1450 – 1910mm
  - Constructed on the floor.
- No extra base preparation required.

AEQ-S32-18ON



## Four post lift for wheel alignment

- Lifting capacity 5500 kg
- Lifting height 1850 mm
- For wheel alignment.
- Width between the columns 3000mm
- Platform length 5080 mm
- Complete with lifting capacity axle lift of 2500kg

AEQ-455-WA51





### Tyre changer

- Wheel rim diameter 10" – 22"
- Max. tyre width 355mm (14")
- Max. tyre diameter 1050mm (41")
- Semiautomatic - the mounting column is turned to the side

AEQ-TS-1022



### Tyre changer

- Wheel rim diameter 10" – 24"
- Max. tyre width 355mm (14")
- Max. tyre diameter 1000mm (39")
- Automatic - the mounting column is tilted back by pressing the pedal

AEQ-TA-1024



### Tyre changer

- Wheel rim diameter 10" – 24"
- Max. tyre width 355mm (14")
- Max. tyre diameter 1000mm (39")
- Automatic - the mounting column is tilted back by pressing the pedal
- Accessories for low profile tire mounting

AEQ-TA-1024H



### Wheel balancer

- Wheel rim diameter 10" – 24"
- Automatic measure for rim diameter and distance
- Balancing cycle time 8s
- The machine is compact
- Standard cone kit

AEQ-B-1024



### Wheel balancer

- Wheel rim diameter 10" – 24"
- Automatic measure for rim diameter and distance
- Laser weight fixing indicator
- Balancing cycle time 8s
- Standard cone kit

AEQ-BL-1024



### Wheel balancer

- Wheel rim diameter 10" – 24"
- Automatic measure for rim diameter and distance
- Automatic measure for rim width
- LCD screen
- Laser weight fixing indicator
- Balancing cycle time 8s

AEQ-BVA-1024



### Tyre changer for trucks

- Wheel rim diameter 13" – 27"
- Max. tyre diameter 1600mm
- Max. tyre width 780mm

AEQ-TT-1327



### Tyre changer for agricultural vehicles

- Wheel rim diameter 14" – 56"
- Max. tyre diameter 1200mm
- Max. tyre width 2500mm

AEQ-TT-1456



### Tyre changer for trucks

- Wheel rim diameter 13" – 24"
- Max. tyre diameter 510mm
- Pneumatic wheel lift
- Balancing cycle time 8s

AEQ-TB-1324L



## Company information

All the automotive training equipment goes with the HS 90230010 CODE FOR Customs

### Remarks:

Delivery time: 4-10 weeks after advanced payment (unless it is written in the offer differently)

Warranty: 12 months for factory defects only.

### Company information:

Baltijos automobilių diagnostikos sistemos UAB

Address: Ateities str. 30G, Kaunas, LT - 52163, Lithuania

Tel./fax.: (+370 - 37) 337842

E-mail: info@autoedu.lt , office@autoedu.lt



# **AUTOEDU**

Automotive technical education equipment

B.A.D.S JSC

Ateities str. 30G, Kaunas

LT – 52163, Lithuania

Tel./Fax: (+370) 37 337 842

Email: [info@autoedu.lt](mailto:info@autoedu.lt), [office@autoedu.lt](mailto:office@autoedu.lt)

[www.automotivetrainingequipment.com](http://www.automotivetrainingequipment.com)