

Utfört:	DAWO
Datum:	2009-10-28
Ersätter:	8042A
Datafil:	SPEC8042_EN_SE_1B.D OC

Vikt / Weight: 4 Kg

OBS! Endast pos.3 får monteras i det explosionsfarliga området.

N.B. In the explosive and hazard area, only pos 3 is allowed to be installed.

☉ = Tätningsmedel / sealing

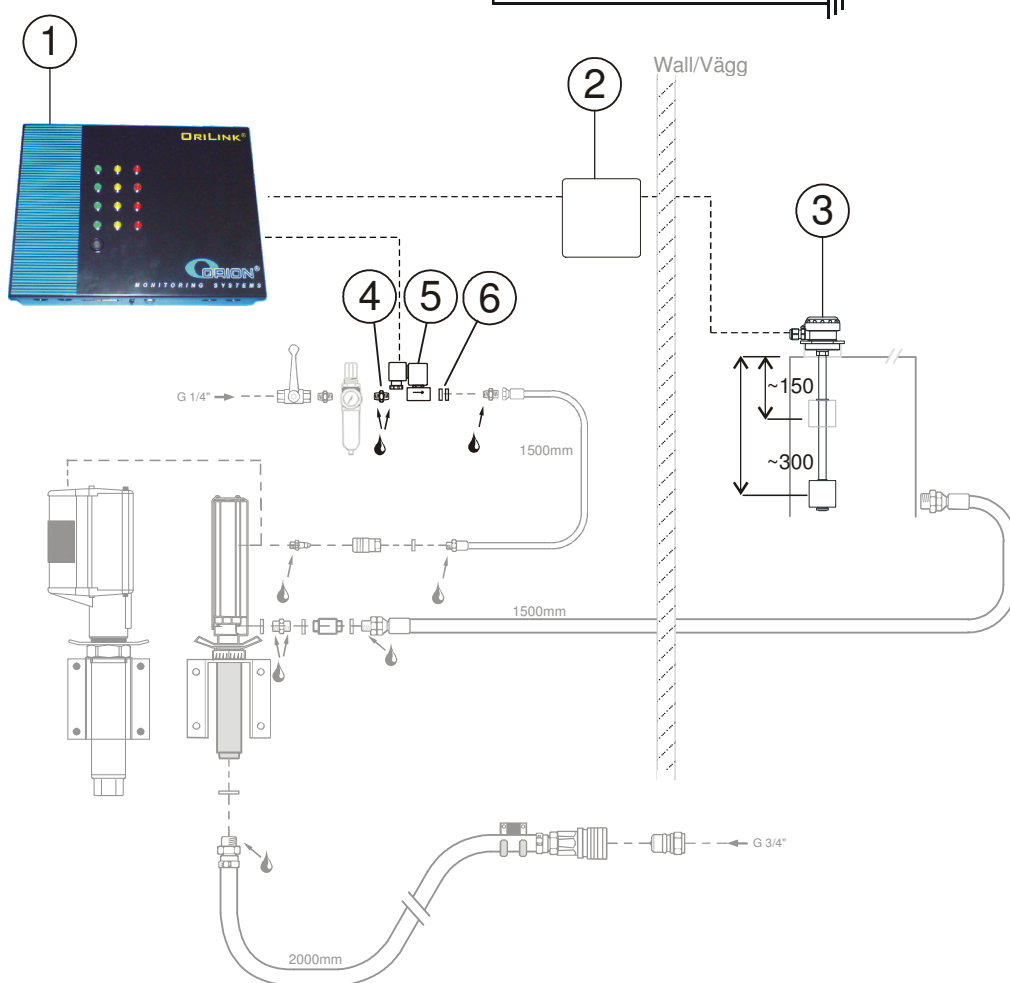
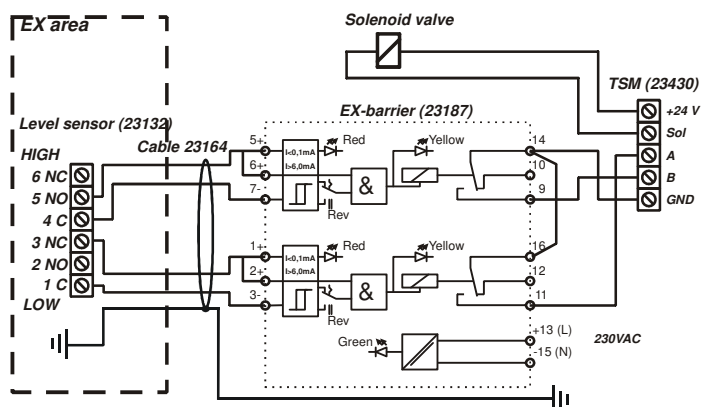

OBS! Kabeln mellan pos 2 och 3 skall vara godkänd för egensäkerhets (blå), art nr 23164 (4x0,75mm²).

N.B. Cable between pos 2 and 3 must be approved for hazardous area (blue), part no 23164 (4x0,75mm²).

	Benämning / Description	Antal Quantity	Art.nr. Part. No.
Pos 1	Övervakningspanel / Control panel	1	23430
Pos 2	EX Barriär / EX Barrier	1	23187
Pos 3	Högnivågivare / High-level sensor	1	23132
Pos. 4	Nippel / Nipple	1	301296
Pos 5	Magnetventil / Soleniod valve 24 VDC	1	48059
Pos. 6	Gummi stål bricka / Rubber steel washer	2	10103529