

# SMX50



**NEW**

**AUTOMATIC  
TYRE CHANGER WITH  
LOCKING CAPACITY  
UP TO 25"**

**SMONTAGOMME  
AUTOMATICO  
CON CAPACITÀ  
DI BLOCCAGGIO  
FINO A 25"**



# SMX50



- Automatic tyre changer with pneumatic **rear tilting post** granting the maximum rigidity to prevent rim damage.
- Smontagomme automatico con **palo ribaltabile pneumaticamente** che garantisce la massima rigidità per non danneggiare il cerchio.



- Pedal-operated inflating device, manometer and CE-certified inflation pressure limiter.
- Dispositivo di gonfiaggio con azionamento a pedale, manometro e limitatore pressione di gonfiaggio a norme CE.

3

- Self-centering turntable to ease bead- breaking of the second tyre bead. Rim locking through opposed- jaws device (**10"- 25" range**), with 80 mm diameter cylinders , which guarantees an optimal grip on all types of rims. Jaws with replaceable tips. New swivel fitting (> speed).
- Piatto autocentrante per agevolare il detallamento del secondo tallone. Sistema di bloccaggio cerchio (**capacità da 10" a 25"**) a griffe contrapposte con cilindri di Ø 80 mm, che garantisce una forza di serraggio ottimale su tutti i tipi di cerchi. Griffe con punte sostituibili. Nuovo raccordo girevole (>velocità).



- **Bead breaker** equipped with adjustable arm system which enables to operate on **large wheels up to 15" in width**.
- **Stallatore** dotato di sistema di regolazione del braccio che permette di operare su **ruote fino a 15" di larghezza**.

5

- Body **with removable pedal unit** for easy maintenance. Pedals positioned in line (rotation included).
- Telaio con **pedaliera estraibile**, per facilitare le operazioni di manutenzione. Pedali posizionati in linea (rotazione inclusa).

6

- **Motor with dual rotation directions** (clockwise/anti-clockwise) and **double speed** by pedal control.
- **Motore** dotato di doppio senso di rotazione e **doppia velocità** con comando a pedale.

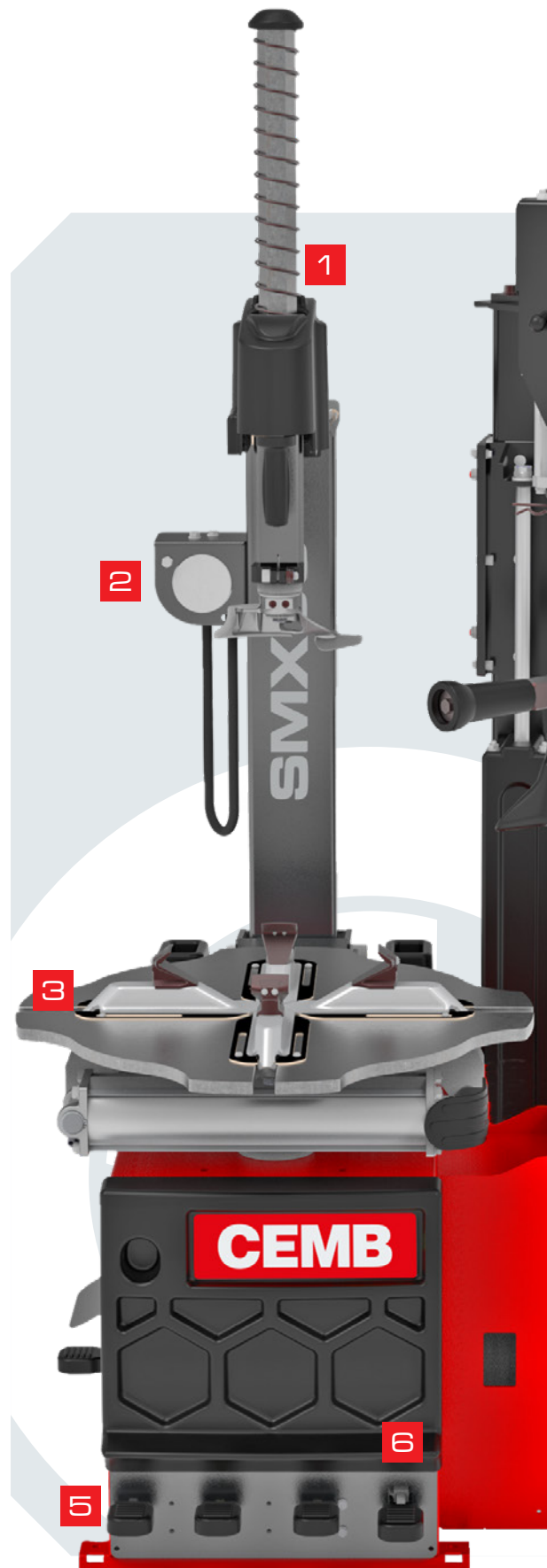

VERSIONS  
ON REQUEST

VERSIONI  
A RICHIESTA



#### TI-VERSION

Version with an effective inflation device for bead seating integrated in clamping jaws.

Versione dotata di efficace sistema di gonfiaggio tubeless incorporato nelle griffe, per l'intallamento dello pneumatico.



#### MOTOINVERTER-VERSION

Version with motor controlled by the new Motoinverter system with progressive variation of speed.

Motore controllato dal nuovo sistema Motoinverter con variazione progressiva della velocità.



#### A-VERSION

A-Version with pneumatic positioning of tool arm.

Versione A con posizionamento pneumatico del braccio porta utensile.

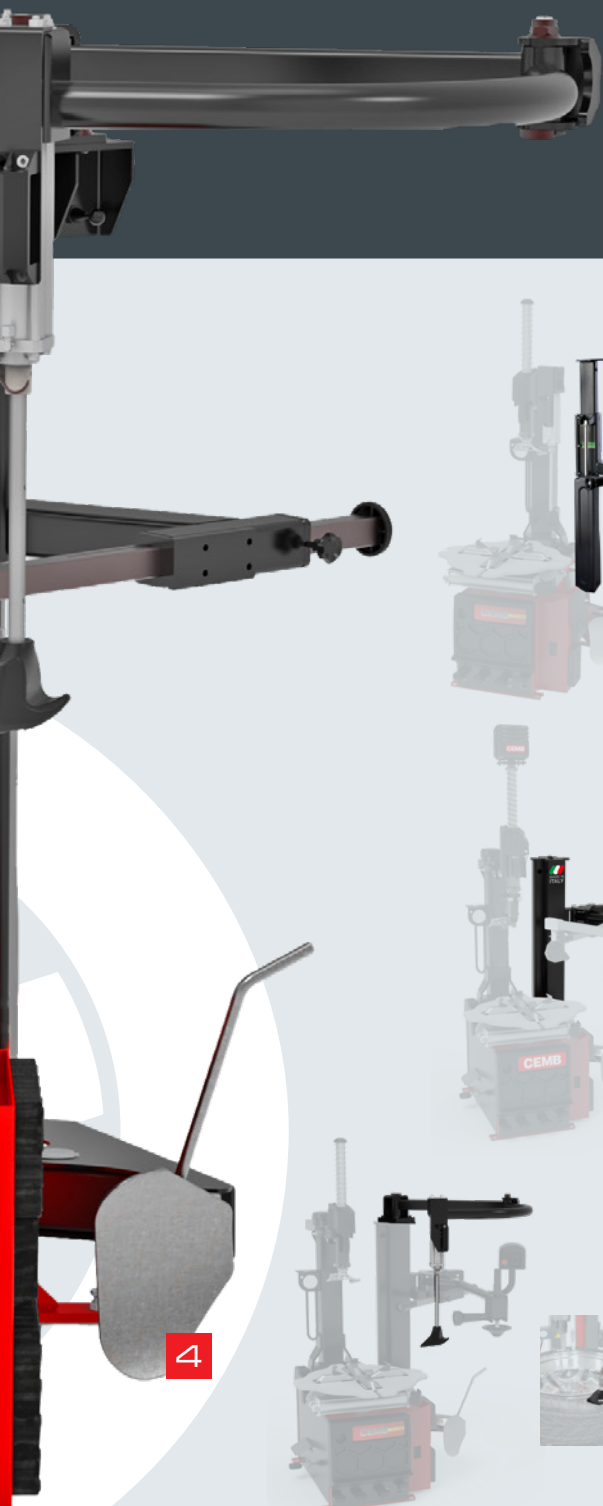

## OPTIONAL ACCESSORIES ACCESSORI OPZIONALI

### HPX-STD

- Professional compact side presser **HPX-STD** recommended to operate on particularly hard and large-sized Run-Flat and UHP Tyres. Compact structure, designed with 1 air cylinder Ø 80 mm to avoid bendings.
- Pressore laterale professionale **HPX-STD** raccomandato per operare su ruote Run-Flat e UHP particolarmente duri e di grandi dimensioni. Struttura compatta progettata con un cilindro ad aria Ø 80 mm che non subisce flessioni.

### HPX-ADVANCE

- Professional lateral presser **HPX-ADVANCE** ideal to operate on particularly hard and large-sized Run-Flat and UHP Tyres. Robust structure with 2 air cylinders of 80 mm to avoid bendings. Equipped with rim pressing tool, standard bead pressing roller arm, bead pressing roller at 90° with pneumatic locking and possibility of operating under the tyre.
- Pressore laterale professionale **HPX-ADVANCE** ideale per operare su ruote Run-Flat e UHP particolarmente duri e di grandi dimensioni. Struttura robusta progettata con 2 cilindri ad aria da 80 mm che non subiscono flessioni. Dotato di premicerchio, un rullo premitallone classico ed un rullo premitallone a 90° con bloccaggio pneumatico e possibilità di operare sul tallone inferiore.

### HPX-FA

- Additional bead-pushing devices which assist during the mounting and demounting of the upper bead. They are recommended on tyres and rims with large diameters and sizes.
- Premitaltoni addizionali. Aiutano in fase di montaggio e smontaggio del tallone superiore. Raccomandati per ruote di grandi dimensioni.

## STANDARD ACCESSORIES - ACCESSORI STANDARD



Bead lever  
Leva



Front head protection (x2)  
Protezione frontale utensile (x2)



Rear head protection (x2)  
Protezione ala utensile (x2)

## OPTIONAL ACCESSORIES - ACCESSORI OPZIONALI



Wheel Lift  
Sollevatore



Roller board  
Kit rulliera



Tubeless inflation system  
Sistema di gonfiaggio TI



4 jaws ALU protection kit  
Kit 4 pezzi protezioni ALU per griffe



Bead breaker blade protection  
Protezione paletta



Plastic lever protection  
Protezione leva in plastica



Run Flat clamp  
Pinza Run Flat



Jaws for motorcycle wheels 14" ÷ 24"  
Kit griffe moto 14" ÷ 24"



Jaws for scooter wheels 8" ÷ 14"  
Kit griffe scooter 8" ÷ 14"

## TECHNICAL DATA - DATI TECNICI

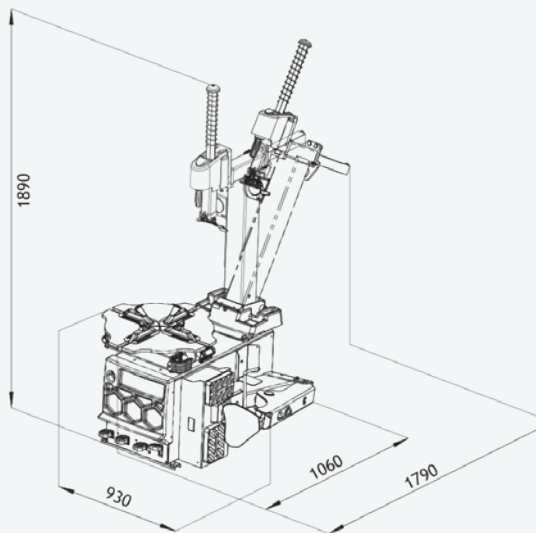

Clamping capacity	Capacità di bloccaggio	10" ÷ 25" (min ÷ max)
Internal clamping	Bloccaggio interno	12" - 25"
External clamping	Bloccaggio esterno	10" - 22"
Max wheel diameter	Diametro massimo ruota	1170 mm (46")
Max wheel width	Larghezza massima ruota	360 mm (14")
Bead breaker force	Forza stallonatore	15000N
3-Phase motor	Potenza motore trifase	0,75 kW 400V - 50/60 Hz (2 speed) 0,55 Kw 400V - 50/60Hz (1 speed)
1-Phase motor	Potenza motore monofase	1.5 kW (Inverter) 230V 50-60Hz
Turntable speed	Velocità di rotazione	8 - 16 rpm (3ph - 2 speed) 7 rpm (3ph - 1 speed) 0 - 16 rpm (1ph - Inverter)
Operating pressure	Pressione di esercizio	8 - 10 bar (116 - 145 psi)
Noise level	Livello di rumorosità	< 70 ± 3 dB (A)
Net weight	Peso Netto	260 kg



# CEMB

BALANCING MACHINES

CEMB S.p.A.

Via Risorgimento, 9  
23826 Mandello del Lario (LC) - Italy  
[www.cemb.com](http://www.cemb.com)



Garage equipment division  
CEMB - ITALY  
Plant and Training Center  
Phone +39 0341 706111  
[garage@cemb.com](mailto:garage@cemb.com)

CEMB USA - BL Systems Inc.  
2873 Ramsey Road  
Gainesville, GA 30501 - USA  
Phone +001 678 717 1050  
Fax +001 678 717 1056  
[sales@cemb-usa.com](mailto:sales@cemb-usa.com)

All the data and features mentioned in this catalogue are purely for information and do not constitute any commitment on the part of our company, which reserves the right to make any and all alterations it may consider suitable without notice.