

SM630



**AUTOMATIC
TYRE CHANGER**

**SMONTAGOMME
AUTOMATICO**



CEMB
GARAGE EQUIPMENT

SM630



- **Rear tilting post** and simultaneous vertical rod and horizontal arm pneumatic locking system, vertical arm with spring return.
- **Palo a ribaltamento posteriore**, sistema pneumatico di bloccaggio simultaneo dell'asta verticale e del braccio orizzontale, ritorno dell'asta verticale a molla.



- Vertical post equipped with **conic buses** and play recovery systems which allow eliminating post flexure.
- Palo verticale dotato di **boccole coniche** e sistemi di recupero giochi che consentono di eliminare le flessioni del palo.

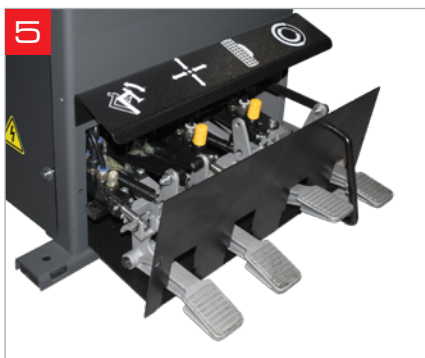

- Body with **extractable pedal unit** to facilitate technical service, **robust reduction unit**, standard CE-certified inflation pressure limiter with provision for gun connection.
- Carcassa con **pedaliera estraibile**, che facilita l'assistenza tecnica, **robusto riduttore**, limitatore pressione di gonfiaggio a norme CE di serie e già predisposto al collegamento della pistola.



- Self-centring plate with **10"-24"** locking capacity, double rotation and two speeds.
- Piatto autocentrante con capacità di bloccaggio **10" - 24"**, doppio senso di rotazione e doppia velocità.



Automatic tyre changer ideal for use in repair shops and tyre shops. Designed to operate on car and light commercial vehicle wheels and on motorcycle wheels with the appropriate accessories.

Smontagomme automatico ideale per utilizzo in officine meccaniche e gommisti, concepito per operare su ruote di autovetture e veicoli commerciali leggeri e, con idonei accessori, su ruote per motociclo.

SM630 HWS



- Bead breaker with **double-acting cylinder**, robust arm and **articulated blade**.
- Stallonatore con **cilindro a doppio effetto**, robusto braccio e **paletta a snodo**.



- Tyre changer completed with side presser **HPX-WS** that allows easily carrying out all the mounting and dismounting operations of Run-flat and UHP tyres. Equipped with rim pressing cone, standard bead pressing roller arm, additional rotating bead pressing arm and bead lifting disc.
- Smontagomme completo di braccio d'aiuto **HPX-WS** per eseguire con facilità tutte le operazioni di montaggio e smontaggio degli pneumatici di tipo Run-Flat e UHP. Dotato di cono di pressione del cerchio, braccio standard con rullo pressore, premiallone aggiuntivo rotante e disco di sollevamento.

STANDARD EQUIPMENT - ACCESSORI STANDARD

The machine is supplied standard with a complete set of plastic protections to operate correctly on alloy rims (mounting head, bead breaker blade, bead lifter lever and self-centring plate jaw).

Macchina fornita di serie di set completo di protezioni plastiche per operare correttamente sui cerchi in lega (testina di montaggio, paletta stallonatrice, leva alzatalloni e griffa del piatto autocentrante).

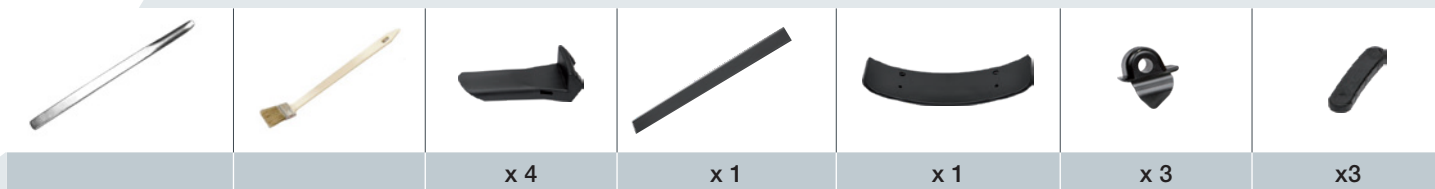

OPTIONAL ACCESSORIES - ACCESSORI OPZIONALI

- Accessories to operate on motorcycle or ATV wheels
- Accessori per operare su ruote per motociclo o ATV



- Set of 4 jaws for bike wheels with 6"-23" rim.
- Set di 4 griffe per ruote moto con cerchi da 6"-23".



- Mounting head for scooter wheels with 8" rims
- Testina di montaggio per ruote scooter con cerchi da 8"



- Bead breaker blade for motorcycle wheels
- Paletta stallonatore per ruote moto



- Quick interchangeable mounting head system, composed by adaptors and 2 mounting heads (one in plastic and one for raised spokes)
- Sistema di cambio rapido testina, composto da adattatori e 2 testine di montaggio (una in plastica e una per razze sporgenti)



- Tool holder
- Portaoggetti

For more information see the complete brochure - Per altri accessori opzionali fare riferimento al catalogo dedicato

TECHNICAL DATA - DATI TECNICI

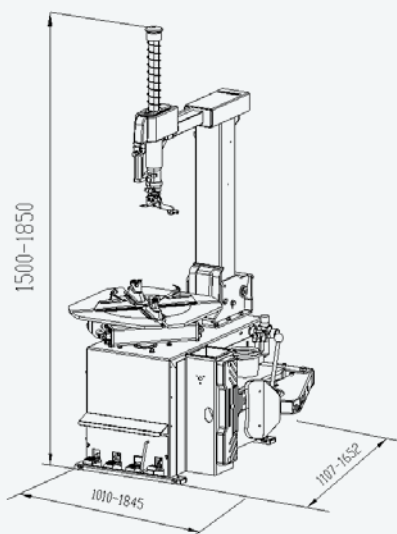

Clamping capacity	Capacità di bloccaggio	10" - 24"
External clamping	Bloccaggio esterno	10" - 22"
Internal clamping	Bloccaggio interno	12" - 24"
Max wheel diameter	Diametro massimo ruota	1000 mm (39.5")
Max wheel width	Larghezza massima ruota	330mm (13")
Bead breaker force	Forza stallonatore	3000 kgf
Turntable speed	Velocità di rotazione	7-14 rpm (7 rpm 1ph)
3-Phase motor	Potenza motore trifase	0.8 - 1.1 kW (400V/50 60Hz/3ph)
1-Phase motor	Potenza motore monofase	0.75 kW
Operating pressure	Pressione di esercizio	10 bar (116 - 145 psi)
Noise level	Livello di rumorosità	< 70 ± 3 dB (A)
Net weight	Peso netto	230 kg
Packing dimensions	Dimensioni imballo	760 x 975 x 950 mm



CEMB

BALANCING MACHINES

CEMB S.p.A.

Via Risorgimento, 9
23826 Mandello del Lario (LC) - Italy
www.cemb.com



Garage equipment division
CEMB - ITALY
Plant and Training Center
Phone +39 0341 706111
garage@cemb.com

SIPAV

Distributore esclusivo per l'Italia:

Via A. Nobel, 21 - 42124 Sesso (RE)
Tel. 0522. 532.711 - Fax 0522.531.828
sipav@sipav.com - www.sipav.com

All the data and features mentioned in this catalogue are purely for information and do not constitute any commitment on the part of our company, which reserves the right to make any and all alterations it may consider suitable without notice.